

**IVECO  
MOTORS**

# **Marine Product Range**

**High Performance Duty Rating - A<sub>1</sub>**

## High Performance Duty Rating – A<sub>1</sub>

---

A<sub>1</sub> - High performance crafts: Full throttle operation restricted within 10% of total use period. Cruising speed at engine RPM less than 90% of rated speed setting - Maximum usage 300 hours per year.

### High Performance (A<sub>1</sub>) rated marine engines

➤ 4000 Series

SDU “Mini” Sail Drive

SDMU “Maxi” Sail Drive

➤ NEF

Konrad 540 Stern Drive

➤ Cursor

➤ Vector



# Duty Ratings Equivalency

IVECO	Caterpillar	Cummins	Detroit Diesel/MTU	John Deere	Volvo
A <sub>1</sub>	E	High Output	High Performance	M5	R5
A <sub>2</sub>	D	Intermittent	High Performance	M4	R4
B	D	Intermittent	Maximum Continuous	M3	R3
C	C	Medium Continuous	Maximum Continuous	M2	R2
D	A/B	Continuous/Heavy Duty	Continuous	M1	R1



# Iveco Repower Suitability

---

In the text of these presentations, an engine is considered to be a “good” or “suitable” replacement if it seems likely that it would be appropriate for the same application as another engine. In other words, if the rated power, displacement, outer dimensions, RPM range, and so on are all comparable, then the engine is considered to be a good or suitable replacement. Data on competitive engines are taken from the manufacturers’ websites, and are current as of January, 2005.



# High Performance (A<sub>1</sub>) Engine Ratings

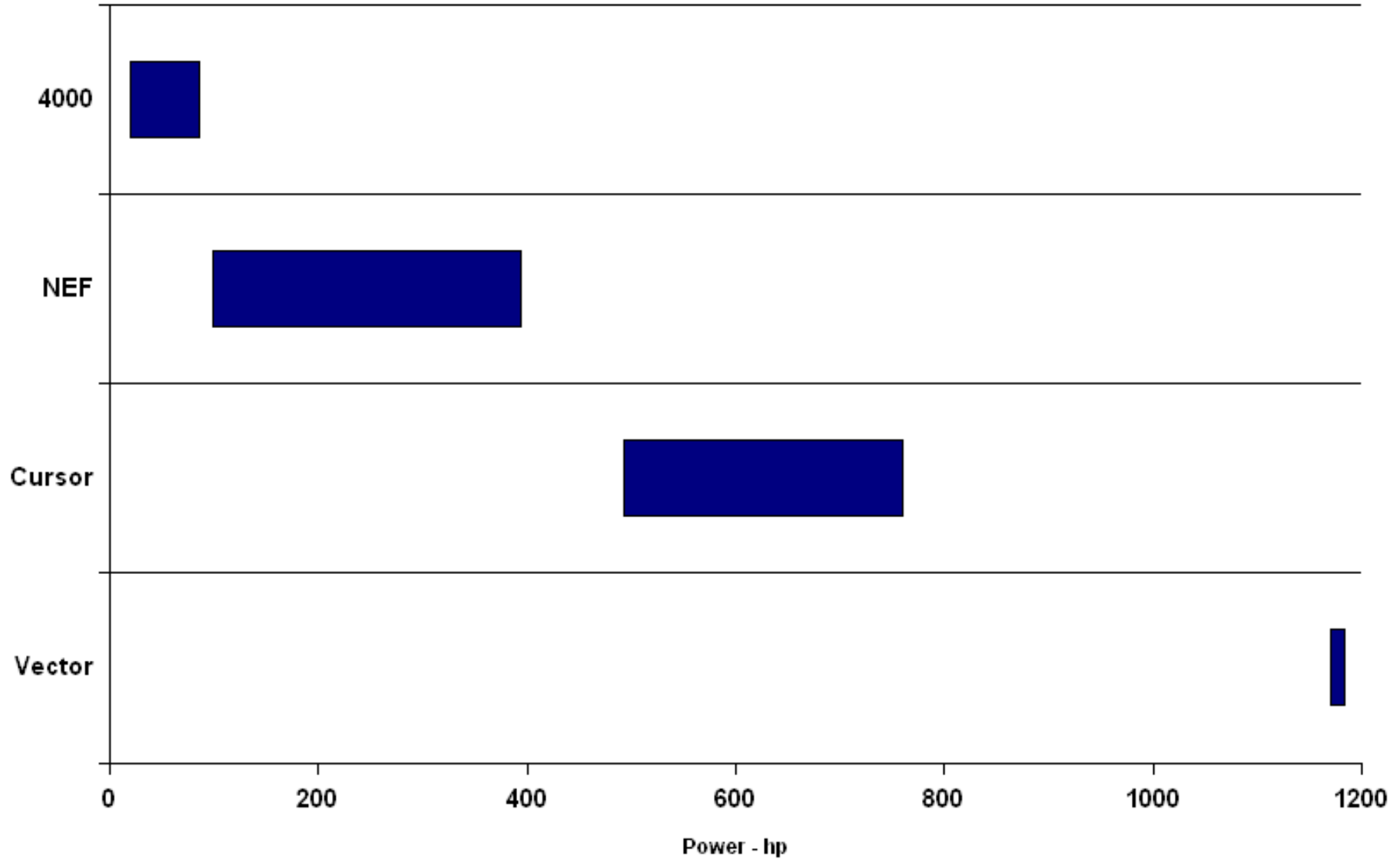

## 4000 Series – A<sub>1</sub> Rating

4021 M20

4031 M30

4041 M40

4241 M41

4341 M60

4341 SRM87



➤ Third digit designates number of cylinders

➤ Last two digits indicate power output in mhp

➤ SR indicates turbocharger

## 4000 Series – A<sub>1</sub> Rating

---

Model	No. Cyl./Asp.	Disp. - L	hp @ RPM
4021 M20	2L - NA	0.686	20 @ 3600
4031 M30	3L - NA	1.028	30 @ 3600
4041 M40	4L - NA	1.372	39 @ 3600
4241 M41	4L - NA	1.995	40 @ 3000
4341 M60	4L - NA	2.199	59 @ 3600
4341 SRM87	4L - TAA	2.199	86 @ 3200

### Suitable replacement for:

- Volvo MD sail boat diesels, D2-55 and D2-75
- Westerbeke 12C Two, 20B Two, 30B Three, 35D Three, 44B Four and 55B Four
- Yanmar 3YM and 3JH marine engine
- Universal Atomic Four

The 4000 Series offers consistently higher power-to-weight ratios than the competition, producing equivalent power from a lower weight engine.

The 4000 Series also features compact exterior dimensions that are smaller than, or comparable to, the engines from the competition.

# 4000 Series (75mm Bore) vs. Volvo – A<sub>1</sub> Rating

Manufacturer	Iveco	Iveco	Iveco	Volvo	Volvo	Volvo
Engine Model	4021 M20	4031 M30	4041 M40	MD2020	MD2030	MD2040
Cylinders	2	3	4	3	3	3
Displacement - L	0.686	1.028	1.372	0.68	0.95	1.5
Bore x Stroke - mm	75 x 77.6	75 x 77.6	75 x 77.6	67 x 64	75 x 72	84 x 90
Compression Ratio	22.8:1	22.8:1	22.8:1	23.5:1	23.0:1	22.0:1
Aspiration	Natural	Natural	Natural	Natural	Natural	Natural
Injection Control	Mechanical	Mechanical	Mechanical	Mechanical	Mechanical	Mechanical
Rated Power - hp	20	30	39	19	29	39
Rated Speed - RPM	3600	3600	3600	3600	3600	3600
Power-to-Weight Ratio - hp/lbs	0.092	0.118	0.133	0.070	0.094	0.089
Length - mm	560	643	726	774	806	851
Width - mm	488	488	488	486	496	550
Height - mm	522	522	549	537	582	691
Weight - lbs	218	254	293	273	309	439

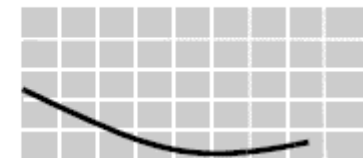
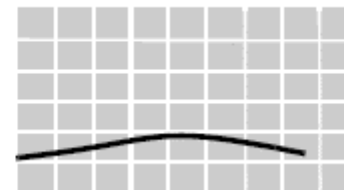
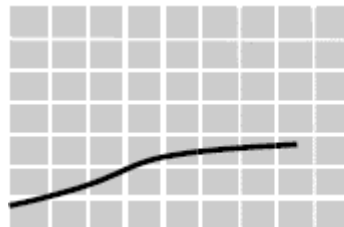

# 4000 Series (88mm Bore) vs. Volvo – A<sub>1</sub> Rating

Manufacturer	Iveco	Iveco	Iveco	Volvo	Volvo
Engine Model	4241 M41	4341 M60	4341 SRM87	D2-55	D2-75
Cylinders	4	4	4	4	4
Displacement - L	1.995	2.199	2.199	2.2	2.2
Bore x Stroke - mm	88 x 82	88 x 90.4	88 x 90.4	84 x 100	84 x 100
Compression Ratio	22.0:1	22.0:1	22.0:1	23.3:1	23.3:1
Aspiration	Natural	Natural	Turbo & Aftercooled	Natural	Turbo & Aftercooled
Injection Control	Mechanical	Mechanical	Mechanical	Mechanical	Mechanical
Rated Power - hp	40	59	86	55	75
Rated Speed - RPM	3000	3600	3200	3000	3000
Power-to-Weight Ratio - hp/lbs	0.079	0.115	0.153	0.103	0.132
Length - mm	895	895	931	717	785
Width - mm	540	540	540	544	545
Height - mm	630	630	642	692	557
Weight - lbs	507	511	562	536	569

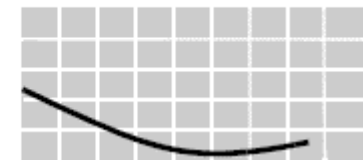
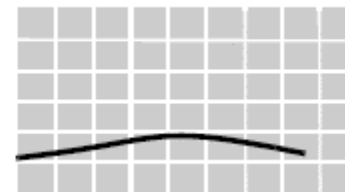
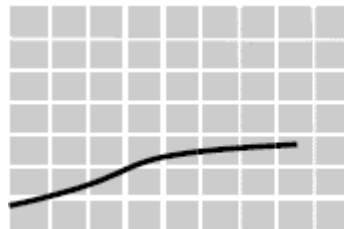

# 4000 Series (75mm Bore) vs. Westerbeke – A<sub>1</sub> Rating

Manufacturer	Iveco	Iveco	Iveco	Westerbeke	Westerbeke	Westerbeke
Engine Model	4021 M20	4031 M30	4041 M40	20B Two	30B Three	35D Three
Cylinders	2	3	4	2	3	3
Displacement - L	0.686	1.028	1.372	0.64	0.95	1.318
Bore x Stroke - mm	75 x 77.6	75 x 77.6	75 x 77.6	76 x 70	76 x 70	78 x 92
Compression Ratio	22.8:1	22.8:1	22.8:1	23.0:1	23.0:1	22.0:1
Aspiration	Natural	Natural	Natural	Natural	Natural	Natural
Injection Control	Mechanical	Mechanical	Mechanical	Mechanical	Mechanical	Mechanical
Rated Power - hp	20	30	39	18	27	31
Rated Speed - RPM	3600	3600	3600	3600	3600	3000
Power-to-Weight Ratio - hp/lbs	0.092	0.118	0.133	0.080	0.099	0.080
Length - mm	560	643	726	704	749	777
Width - mm	488	488	488	508	508	542
Height - mm	522	522	549	516	516	574
Weight - lbs	218	254	293	225	274	386

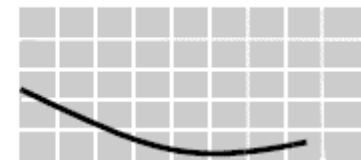
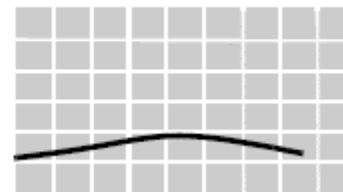
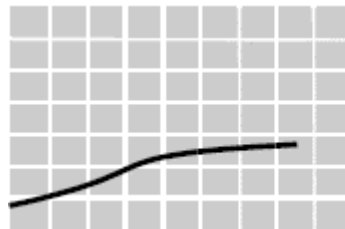

# 4000 Series (88mm Bore) vs. Westerbeke – A<sub>1</sub> Rating

Manufacturer	Iveco	Iveco	Iveco	Westerbeke	Westerbeke
Engine Model	4241 M41	4341 M60	4341 SRM87	44B Four	55B Four
Cylinders	4	4	4	4	4
Displacement - L	1.995	2.199	2.199	1.758	2.18
Bore x Stroke - mm	88 x 82	88 x 90.4	88 x 90.4	78 x 92	85 x 96
Compression Ratio	22.0:1	22.0:1	22.0:1	22.0:1	21.5:1
Aspiration	Natural	Natural	Turbo & Aftercooled	Natural	Natural
Injection Control	Mechanical	Mechanical	Mechanical	Mechanical	Mechanical
Rated Power - hp	40	59	86	44	55
Rated Speed - RPM	3000	3600	3200	3000	3000
Power-to-Weight Ratio - hp/lbs	0.079	0.115	0.153	0.106	0.123
Length - mm	895	895	931	866	890
Width - mm	540	540	540	541	542
Height - mm	630	630	642	584	809
Weight - lbs	507	511	562	416	448

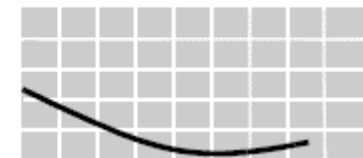
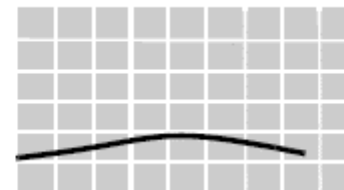
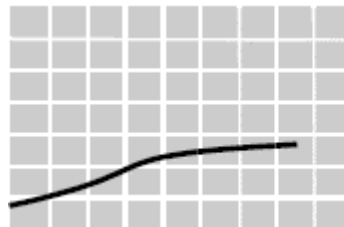

# 4000 Series (75mm Bore) vs. Yanmar – A<sub>1</sub> Rating

Manufacturer	Iveco	Iveco	Yanmar	Yanmar
Engine Model	4031 M30	4041 M40	3YM	3JH
Cylinders	3	4	3	3
Displacement - L	1.028	1.372	1.115	1.64
Bore x Stroke - mm	75 x 77.6	75 x 77.6	76 x 82	88 x 90
Compression Ratio	22.8:1	22.8:1		
Aspiration	Natural	Natural	Natural	Natural
Injection Control	Mechanical	Mechanical		
Rated Power - hp	30	39	30	39
Rated Speed - RPM	3600	3600	3600	3000
Power-to-Weight Ratio - hp/lbs	0.118	0.133	0.111	0.102
Length - mm	643	726	716	770
Width - mm	488	488	462	518
Height - mm	522	549	545	623
Weight - lbs	254	293	271	381

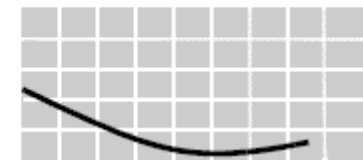
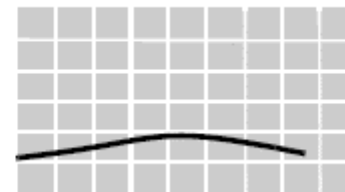
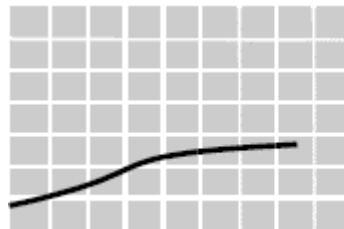

## 4000 Series vs. Universal – A<sub>1</sub> Rating

The 4000 Series makes an excellent replacement for aging and outdated Universal Atomic Fours

- 4031 M30 makes identical power from only three cylinders
- 4041 M40 makes 33% more power
- Both 4031 M30 and 4041 M40 are lighter than the Atomic Four, with comparable outer dimensions
- Upgrade points:
  - **Diesel is safer than gasoline**
  - **Diesel engines get better fuel efficiency**
  - **Diesel engines are more durable**
  - **No more carburetors**

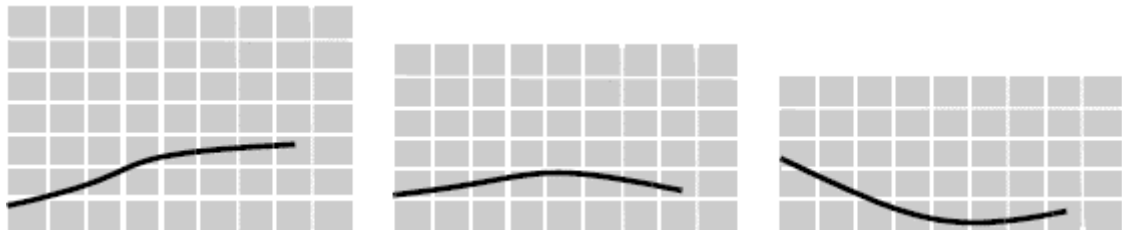

## SDU – “Mini”

- For use with:
  - 4021 M20
  - 4031 M30
  - 4041 M40
- 2.18:1 Reduction Ratio

SDU drive features light weight and low drag without sacrificing durability or reliability. Frontal area is reduced by minimizing the width of the drive to 1.654”

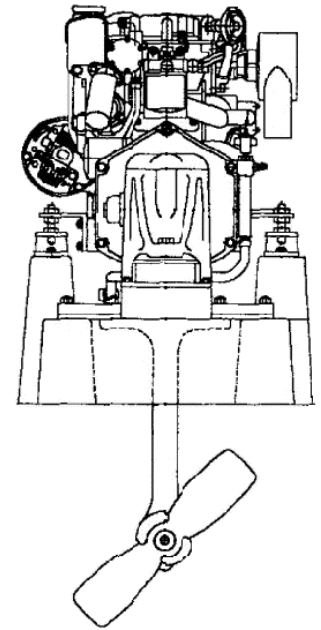
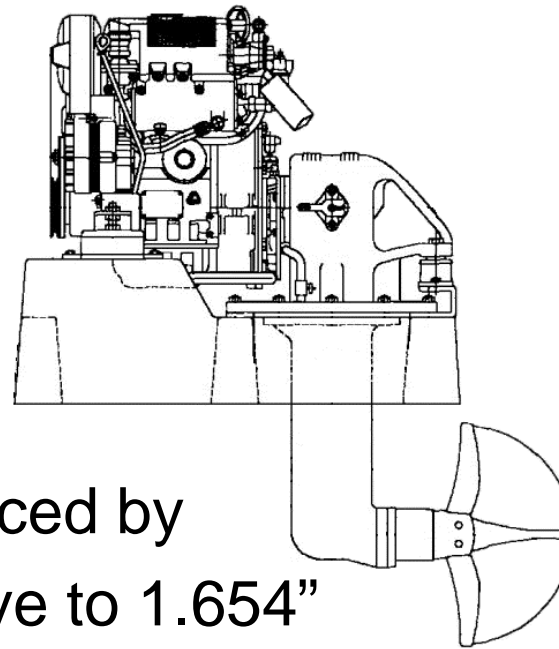

## SDMU – “Maxi”

- For use with:
  - 4241 M41
  - 4341 M60
  - 4341 SRM87
- 1.92:1 Reduction Ratio

SDMU drive features light weight and low drag without sacrificing durability or reliability. Frontal area is reduced by minimizing the width of the drive to 2.087”

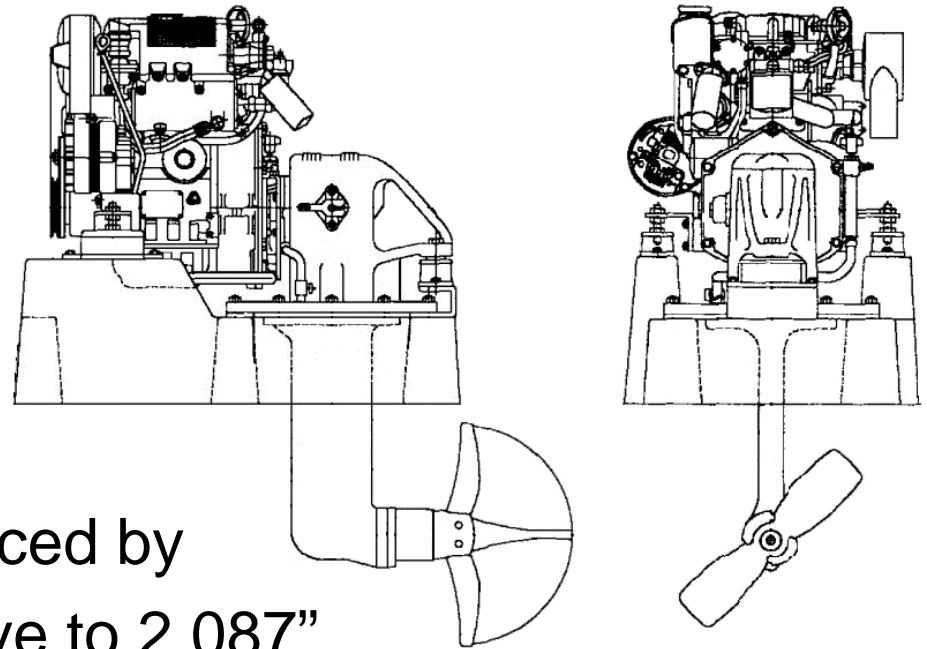

## NEF – A<sub>1</sub> Rating

N45 MNA M10	-	“NEF 100”
N67 MNA M15	-	“NEF 150”
N40 ENT M25	-	“NEF 250”
N67 MNT M28	-	“NEF 280”
N60 ENT M37	-	“NEF 370”
N60 ENT M37SD	-	“NEF 370” (Stern Drive)
N60 ENT M40	-	“NEF 400”



- First character indicates NEF
- Second & third characters indicate displacement, e.g. 67→6.7L
- Fourth character denotes Mechanical or Electronic fuel injection
- Sixth character indicates naturally-Aspirated or Turbocharged-aftercooled
- Last two numbers show approximate power\*, e.g. 28→280mhp

\*Horsepower rating based on A<sub>1</sub> duty rating

## NEF – A<sub>1</sub> Rating

---

<b>Model</b>	<b>No. Cyl./Asp.</b>	<b>Disp. - L</b>	<b>hp @ RPM</b>
N45 MNA M10	4L - NA	4.5	99 @ 2800
N67 MNA M15	6L - NA	4.5	148 @ 2800
N40 ENT M25	4L - TAA	3.9	247 @ 2800
N67 MNT M28	6L - TAA	6.7	276 @ 2800
N60 ENT M37	6L - TAA	5.9	365 @ 2800
N60 ENT M37SD	6L - TAA	5.9	365 @ 3000
N60 ENT M40	6L - TAA	5.9	394 @ 3000

### Suitable replacement for:

- Caterpillar 3054, 3056, 3126, 3126B and C7 marine engines
- Cummins 3.9L, 4.2L and 5.9L marine engines
- John Deere 4045 and 6068 marine engines
- Volvo D4-210, D6-310, TAMD41 / KAMD43, TAMD63 and D7
- Westerbeke 108C Six and Century Series marine engines
- Yanmar LH, LP and LY marine engines

The NEF produces a higher power-to-weight ratio than the majority of the competition.

The NEF also features generally comparable or smaller exterior dimensions than competitive engines.

# NEF 4-Cylinder vs. Caterpillar – A<sub>1</sub> Rating

Manufacturer	Iveco	Iveco	Caterpillar
Engine Model	N45	N40	3054*
Cylinders	4	4	4
Displacement - L	4.5	3.9	4.0
Bore x Stroke - mm	104 x 132	102 x 120	100 x 127
Compression Ratio	17.5:1	17.5:1	17.25:1
Aspiration	Natural	Turbo & Aftercooled	Turbo
Injection Control	Mechanical	Electronic	Mechanical
Rated Power - hp	99	247	108
Rated Speed - RPM	2800	2800	2400
Power-to-Weight Ratio - hp/lbs	0.102	0.231	0.116
Length - mm	830	983	1160
Width - mm	683	780	703
Height - mm	830	785	830
Weight - lbs	970	1069	933

\*This engine is not rated for this duty rating.  
The rating provided is from the next rating down,  
Medium Duty (C).

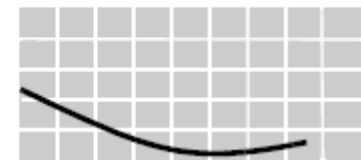
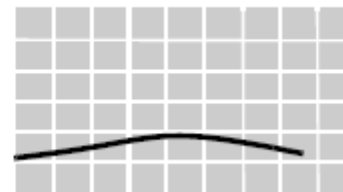
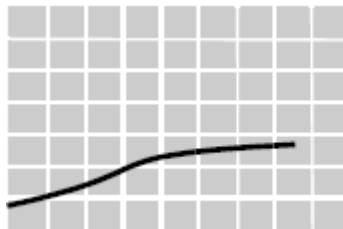

# NEF 6-Cylinder vs. Caterpillar – A<sub>1</sub> Rating

Manufacturer	Iveco	Iveco	Caterpillar	Caterpillar
Engine Model	N67	N60	3056*	3126B / C7
Cylinders	6	6	6	6
Displacement - L	6.7	5.9	6.0	7.24
Bore x Stroke - mm	104 x 132	102 x 120	100 x 127	110 x 127
Compression Ratio	17.5:1	17.5:1	16.0:1	
Aspiration	Turbo & Aftercooled	Turbo & Aftercooled	Turbo & Aftercooled	Turbo & Aftercooled
Injection Control	Mechanical	Electronic	Mechanical	Electronic
Rated Power - hp	276	394	205	455
Rated Speed - RPM	2800	3000	2500	2800
Power-to-Weight Ratio - hp/lbs	0.207	0.300	0.156	0.255
Length - mm	1236	1333	1068	1177
Width - mm	780	805	800	890
Height - mm	793	774	917	917
Weight - lbs	1334	1312	1312	1782

\*This engine is not rated for this duty rating.  
The rating provided is from the next rating down,  
Medium Duty (C).

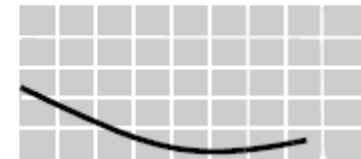
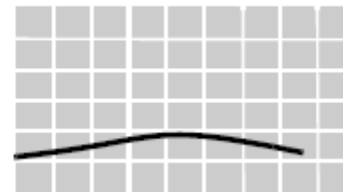
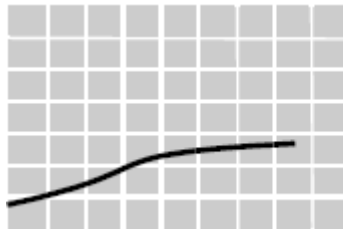

# NEF 4-Cylinder vs. Cummins – A<sub>1</sub> Rating

Manufacturer	Iveco	Iveco	Cummins	Cummins
Engine Model	N45	N40	4B*	4.2
Cylinders	4	4	4	4
Displacement - L	4.5	3.9	3.9	4.2
Bore x Stroke - mm	104 x 132	102 x 120	102 x 120	94 x 100
Compression Ratio	17.5:1	17.5:1		16.5:1
Aspiration	Natural	Turbo & Aftercooled	Turbo	Turbo & Aftercooled
Injection Control	Mechanical	Electronic	Mechanical	
Rated Power - hp	99	247	148	296
Rated Speed - RPM	2800	2800	2800	3800
Power-to-Weight Ratio - hp/lbs	0.102	0.231	0.159	0.255
Length - mm	830	983	780	1041
Width - mm	683	780	704	726
Height - mm	830	785	771	767
Weight - lbs	970	1069	932	1161

\*This engine is not rated for this duty rating.  
The rating provided is from the next rating down,  
Pleasure/Commercial Duty (A<sub>2</sub>).

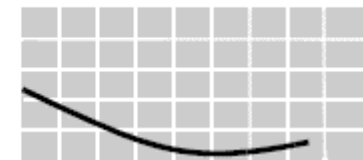
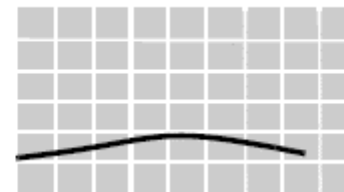
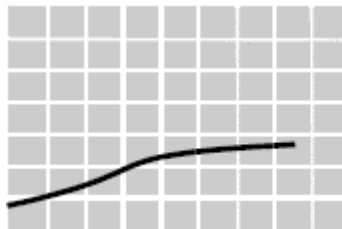

# NEF 6-Cylinder vs. Cummins – A<sub>1</sub> Rating

Manufacturer	Iveco	Iveco	Cummins	Cummins
Engine Model	N67	N60	6B*	QSB
Cylinders	6	6	6	6
Displacement - L	6.7	5.9	5.9	5.9
Bore x Stroke - mm	104 x 132	102 x 120	102 x 120	102 x 120
Compression Ratio	17.5:1	17.5:1		
Aspiration	Turbo & Aftercooled	Turbo & Aftercooled	Turbo & Aftercooled	Turbo & Aftercooled
Injection Control	Mechanical	Electronic	Mechanical	Electronic
Rated Power - hp	276	394	311	375
Rated Speed - RPM	2800	3000	2800	3000
Power-to-Weight Ratio - hp/lbs	0.207	0.300	0.273	0.289
Length - mm	1236	1333	1028	1036
Width - mm	780	805	826	879
Height - mm	793	774	837	858
Weight - lbs	1334	1312	1140	1296

\*This engine is not rated for this duty rating.  
The rating provided is from the next rating down,  
Pleasure/Commercial Duty (A<sub>2</sub>).

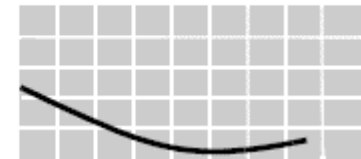
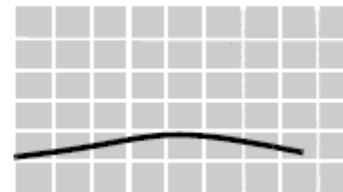
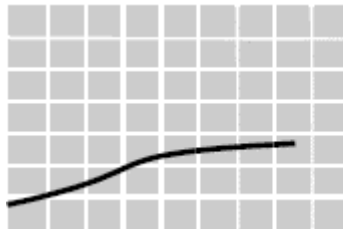

# NEF 4-Cylinder vs. John Deere – A<sub>1</sub> Rating

Manufacturer	Iveco	Iveco	John Deere
Engine Model	N45	N40	4045*
Cylinders	4	4	4
Displacement - L	4.5	3.9	4.5
Bore x Stroke - mm	104 x 132	102 x 120	106 x 127
Compression Ratio	17.5:1	17.5:1	17.6:1
Aspiration	Natural	Turbo & Aftercooled	Turbo
Injection Control	Mechanical	Electronic	Electronic
Rated Power - hp	99	247	135
Rated Speed - RPM	2800	2800	2600
Power-to-Weight Ratio - hp/lbs	0.102	0.231	0.133
Length - mm	830	983	885
Width - mm	683	780	712
Height - mm	830	785	912
Weight - lbs	970	1069	1018

\*This engine is not rated for this duty rating.  
The rating provided is from the next rating down, Light Duty (B).

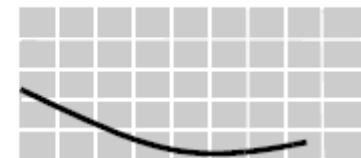
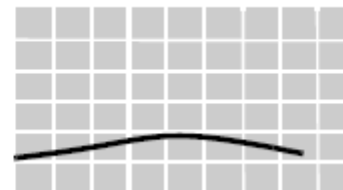
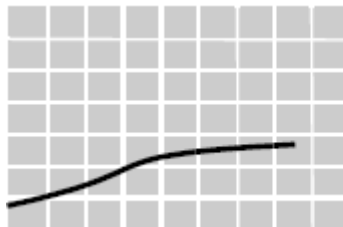

# NEF 6-Cylinder vs. John Deere – A<sub>1</sub> Rating

Manufacturer	Iveco	Iveco	John Deere
Engine Model	N67	N60	6068
Cylinders	6	6	6
Displacement - L	6.7	5.9	6.8
Bore x Stroke - mm	104 x 132	102 x 120	106 x 127
Compression Ratio	17.5:1	17.5:1	17.0:1
Aspiration	Turbo & Aftercooled	Turbo & Aftercooled	Turbo
Injection Control	Mechanical	Electronic	Electronic
Rated Power - hp	276	394	300
Rated Speed - RPM	2800	3000	2600
Power-to-Weight Ratio - hp/lbs	0.207	0.300	0.214
Length - mm	1236	1333	1183
Width - mm	780	805	721
Height - mm	793	774	946
Weight - lbs	1334	1312	1402

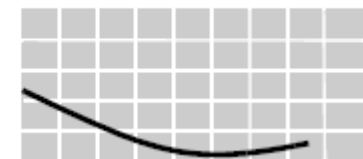
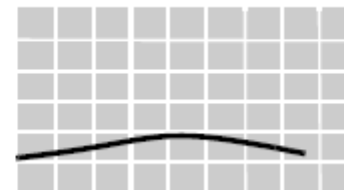
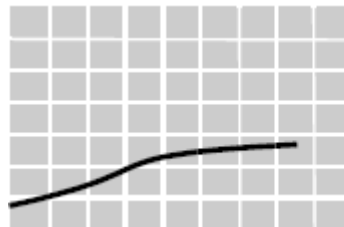

# NEF 4-Cylinder vs. Volvo – A<sub>1</sub> Rating

Manufacturer	Iveco	Iveco	Volvo	Volvo
Engine Model	N45	N40	D4-210	TAMD41 / KAMD43
Cylinders	4	4	4	6
Displacement - L	4.5	3.9	3.7	3.6
Bore x Stroke - mm	104 x 132	102 x 120	103 x 110	92 x 90
Compression Ratio	17.5:1	17.5:1	17.5:1	17.5:1
Aspiration	Natural	Turbo & Aftercooled	Turbo & Aftercooled	Turbo & Aftercooled
Injection Control	Mechanical	Electronic	Electronic	Mechanical
Rated Power - hp	99	247	210	230
Rated Speed - RPM	2800	2800	3500	3900
Power-to-Weight Ratio - hp/lbs	0.102	0.231	0.174	0.207
Length - mm	830	983	1138	1221
Width - mm	683	780	820	687
Height - mm	830	785	780	758
Weight - lbs	970	1069	1204	1109

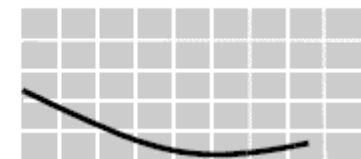
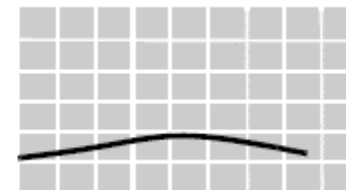
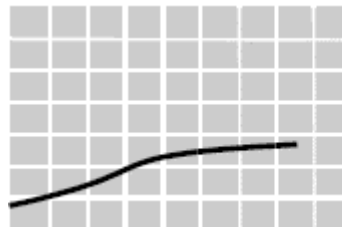

# NEF 6-Cylinder vs. Volvo – A<sub>1</sub> Rating

Manufacturer	Iveco	Iveco	Volvo	Volvo	Volvo
Engine Model	N67	N60	D6-310*	TAMD63*	D7(A/C) T(A)*
Cylinders	6	6	6	6	6
Displacement - L	6.7	5.9	5.5	5.5	7.15
Bore x Stroke - mm	104 x 132	102 x 120	103 x 110	98 x 120	108 x 130
Compression Ratio	17.5:1	17.5:1	17.5:1	15.0:1	17.6:1
Aspiration	Turbo & Aftercooled	Turbo & Aftercooled	Turbo & Aftercooled	Turbo & Aftercooled	Turbo & Aftercooled
Injection Control	Mechanical	Electronic	Electronic	Electronic	Mechanical
Rated Power - hp	276	394	310	370	265
Rated Speed - RPM	2800	3000	3500	2800	2300
Power-to-Weight Ratio - hp/lbs	0.207	0.300	0.214	0.226	0.174
Length - mm	1236	1333	1439	1365	
Width - mm	780	805	820	766	
Height - mm	793	774	780	892	
Weight - lbs	1334	1312	1446	1636	1521

\*These engines are not rated for this duty rating.  
 The D6-310 and TAMD63 ratings provided are from the next rating down, Pleasure/Commercial Duty (A<sub>2</sub>).  
 The D7 rating provided is from the next rating down, Medium Duty (C).

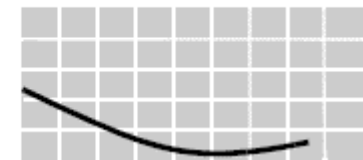
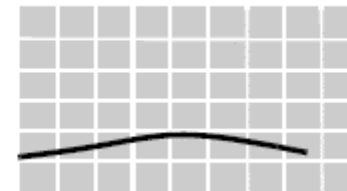
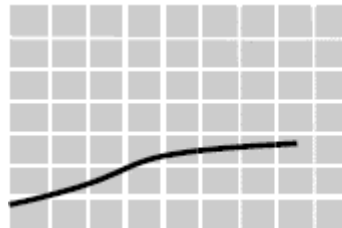

# NEF 4-Cylinder vs. Westerbeke – A<sub>1</sub> Rating

Manufacturer	Iveco	Iveco	Westerbeke	Westerbeke	Westerbeke
Engine Model	N45	N40	108C Six	Century 80-N4	Century 110-T4
Cylinders	4	4	6	4	4
Displacement - L	4.5	3.9	4.05	4.3	4.3
Bore x Stroke - mm	104 x 132	102 x 120	92 x 102	105 x 125	105 x 125
Compression Ratio	17.5:1	17.5:1	21.0:1	17.0:1	17.0:1
Aspiration	Natural	Turbo & Aftercooled	Natural	Natural	Turbo
Injection Control	Mechanical	Electronic	Mechanical	Mechanical	Mechanical
Rated Power - hp	99	247	108	80	110
Rated Speed - RPM	2800	2800	3600	2500	2400
Power-to-Weight Ratio - hp/lbs	0.102	0.231	0.116	0.097	0.131
Length - mm	830	983	1305	1015	993
Width - mm	683	780	683	641	718
Height - mm	830	785	743	814	814
Weight - lbs	970	1069	932	822	838

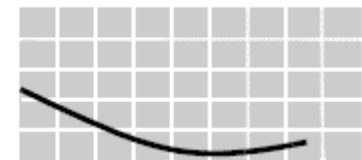
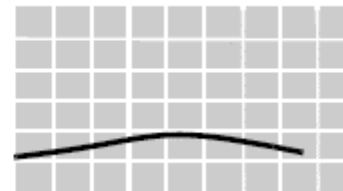
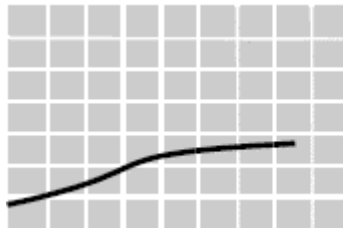

# NEF 6-Cylinder vs. Westerbeke – A<sub>1</sub> Rating

Manufacturer Engine Model	Iveco N67	Iveco N60	Westerbeke Century 120-N6	Westerbeke Century 170-T6
Cylinders	6	6	6	6
Displacement - L	6.7	5.9	6.5	6.5
Bore x Stroke - mm	104 x 132	102 x 120	105 x 125	105 x 125
Compression Ratio	17.5:1	17.5:1	17.0:1	17.0:1
Aspiration	Turbo & Aftercooled	Turbo & Aftercooled	Natural	Turbo
Injection Control	Mechanical	Electronic	Mechanical	Mechanical
Rated Power - hp	276	394	120	170
Rated Speed - RPM	2800	3000	2500	2500
Power-to-Weight Ratio - hp/lbs	0.207	0.300	0.117	0.156
Length - mm	1236	1333	1261	1237
Width - mm	780	805	641	711
Height - mm	793	774	827	827
Weight - lbs	1334	1312	1026	1089

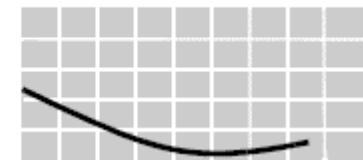
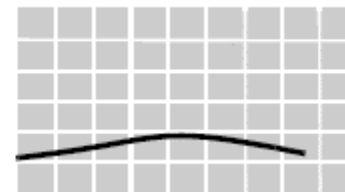
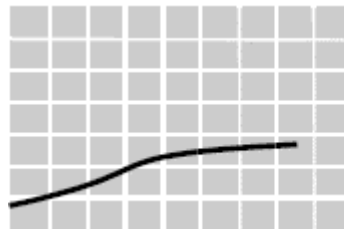

# NEF 4-Cylinder vs. Yanmar – A<sub>1</sub> Rating

Manufacturer	Iveco	Iveco	Yanmar	Yanmar
Engine Model	N45	N40	LH	LP
Cylinders	4	4	4	6
Displacement - L	4.5	3.9	3.455	4.164
Bore x Stroke - mm	104 x 132	102 x 120	100 x 110	94 x 100
Compression Ratio	17.5:1	17.5:1		
Aspiration	Natural	Turbo & Aftercooled	Turbo & Aftercooled	Turbo & Aftercooled
Injection Control	Mechanical	Electronic	Mechanical	Mechanical
Rated Power - hp	99	247	240	315
Rated Speed - RPM	2800	2800	3300	3800
Power-to-Weight Ratio - hp/lbs	0.102	0.231	0.298	0.350
Length - mm	830	983	1059	1205
Width - mm	683	780	719	700
Height - mm	830	785	789	812
Weight - lbs	970	1069	805	899

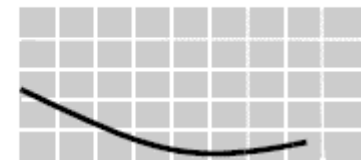
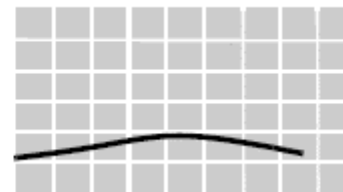
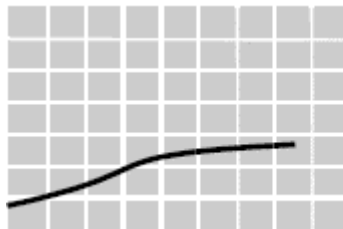

# NEF 6-Cylinder vs. Yanmar – A<sub>1</sub> Rating

Manufacturer	Iveco	Iveco	Yanmar	Yanmar
Engine Model	N67	N60	LY	LY2
Cylinders	6	6	6	6
Displacement - L	6.7	5.9	5.184	5.813
Bore x Stroke - mm	104 x 132	102 x 120	100 x 110	106 x 110
Compression Ratio	17.5:1	17.5:1		
Aspiration	Turbo & Aftercooled	Turbo & Aftercooled	Turbo & Aftercooled	Turbo & Aftercooled
Injection Control	Mechanical	Electronic	Mechanical	Mechanical
Rated Power - hp	276	394	370	440
Rated Speed - RPM	2800	3000	3300	3300
Power-to-Weight Ratio - hp/lbs	0.207	0.300	0.317	0.373
Length - mm	1236	1333	1275	1275
Width - mm	780	805	819	819
Height - mm	793	774	843	843
Weight - lbs	1334	1312	1168	1179

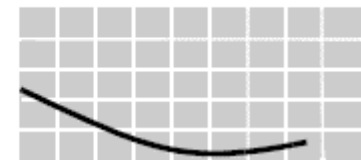
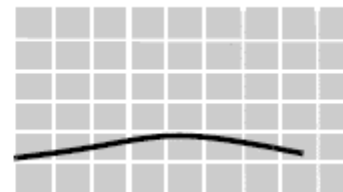
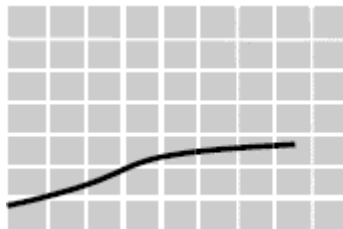

## Konrad 520 Stern Drive – A<sub>1</sub> Rating

---

NEF 370SD features a Konrad Marine 520 stern drive.

Konrad Marine designs and builds the best stern drives in the market with an emphasis on durability, dependability and performance.

The 520 drive is designed as a direct replacement for the Mercury Marine TRS drive.

Propellers available

- Konrad recommends PowerTech! 3- and 4-blade propellers
- 20" max diameter
- 19-spline prop shaft
- Same props as MerCruiser Bravo II

Transom cutout

- Same as MerCruiser TR & TRS

More information available at

[www.KonradMarine.com](http://www.KonradMarine.com)



## Cursor – A<sub>1</sub> Rating

C78 ENT M50	-	“Cursor 500”
C78 ENT M55	-	“Cursor 550”
C13 ENT M77	-	“Cursor 770”



- First character indicates Cursor
- Second & third digits indicate displacement: 78→7.8L, 13→13L
- Fourth letter denotes Electronic fuel injection
- Sixth character indicates Turbocharged-aftercooled
- Last two numbers show approximate power\*, e.g. 55→550mhp

\* Horsepower rating varies with duty rating

## Cursor – A<sub>1</sub> Rating

---

Model	No. Cyl./Asp.	Disp. - L	hp @ RPM
C78 ENT M50	6L - TAA	7.8	493 @ 2600
C78 ENT M55	6L - TAA	7.8	543 @ 2600
C13 ENT M77	6L - TAA	12.88	760 @ 2300

Suitable replacement for:

- Caterpillar 3126, 3126B, C7, C9, C12 and 3196 marine engines
- Cummins 8.3L and 10.8L marine engines
- John Deere 6081 and 6125 marine engines
- Volvo 9.4L, 9.6L and 12.1L marine engines
- Yanmar CX Series and 6SY Series

Cursor offers generally competitive or superior power-to-weight ratios, from comparable or smaller outer dimensions.

# Cursor vs. Caterpillar – A<sub>1</sub> Rating

Manufacturer	Iveco	Iveco	Caterpillar	Caterpillar	Caterpillar
Engine Model	Cursor 8	Cursor 13	3126B / C7	C9	3196 / C12
Cylinders	6	6	6	6	6
Displacement - L	7.8	12.9	7.24	8.8	12.0
Bore x Stroke - mm	115 x 125	135 x 150	110 x 127	112 x 149	130 x 150
Compression Ratio	16.0:1	16.0:1			
Aspiration	Turbo & Aftercooled	Turbo & Aftercooled	Turbo & Aftercooled	Turbo & Aftercooled	Turbo & Aftercooled
Injection Control	Electronic	Electronic	Electronic	Electronic	Electronic
Rated Power - hp	543	760	455	503	705
Rated Speed - RPM	2600	2300	2800	2500	2300
Power-to-Weight Ratio - hp/lbs	0.271	0.250	0.255	0.241	0.272
Length - mm	1243	1465	1177	1198	1574
Width - mm	855	1088	890	974	969
Height - mm	954	1040	917	983	1005
Weight - lbs	2006	3042	1782	2086	2588

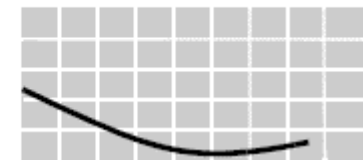
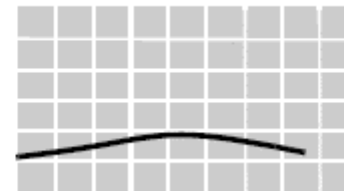
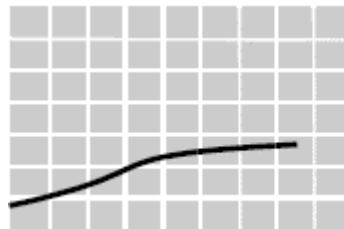

# Cursor vs. Cummins – A<sub>1</sub> Rating

Manufacturer	Iveco	Iveco	Cummins	Cummins
Engine Model	Cursor 8	Cursor 13	6C / QSC	QSM
Cylinders	6	6	6	6
Displacement - L	7.8	12.9	8.3	10.8
Bore x Stroke - mm	115 x 125	135 x 150	114 x 135	125 x 147
Compression Ratio	16.0:1	16.0:1		
Aspiration	Turbo & Aftercooled	Turbo & Aftercooled	Turbo & Aftercooled	Turbo & Aftercooled
Injection Control	Electronic	Electronic	Electronic	Electronic
Rated Power - hp	543	760	533	660
Rated Speed - RPM	2600	2300	2600	2300
Power-to-Weight Ratio - hp/lbs	0.271	0.250	0.277	0.267
Length - mm	1243	1465	1426	1354
Width - mm	855	1088	978	981
Height - mm	954	1040	982	1012
Weight - lbs	2006	3042	1924	2475

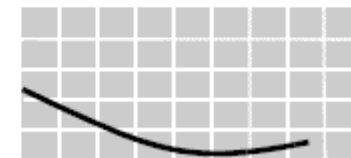
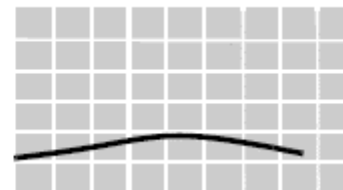
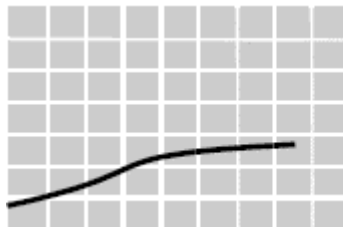

# Cursor vs. John Deere – A<sub>1</sub> Rating

Manufacturer	Iveco	Iveco	John Deere	John Deere
Engine Model	Cursor 8	Cursor 13	6081*	6125*
Cylinders	6	6	6	6
Displacement - L	7.8	12.9	8.1	12.5
Bore x Stroke - mm	115 x 125	135 x 150	116 x 129	127 x 165
Compression Ratio	16.0:1	16.0:1	15.7:1	17.0:1
Aspiration	Turbo & Aftercooled	Turbo & Aftercooled	Turbo & Aftercooled	Turbo
Injection Control	Electronic	Electronic	Electronic	Electronic
Rated Power - hp	543	760	375	526
Rated Speed - RPM	2600	2300	2400	2100
Power-to-Weight Ratio - hp/lbs	0.271	0.250	0.199	0.167
Length - mm	1243	1465	1299	1426
Width - mm	855	1088	787	850
Height - mm	954	1040	1005	1138
Weight - lbs	2006	3042	1881	3142

\*These engines are not rated for this duty rating. The rating provided is from the next rating down, Pleasure/Commercial Duty (A<sub>2</sub>).

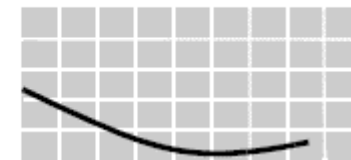
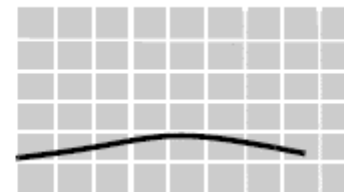
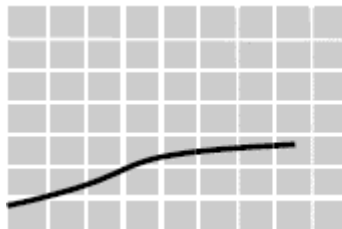

# Cursor vs. Volvo – A<sub>1</sub> Rating

Manufacturer	Iveco	Iveco	Volvo	Volvo	Volvo
Engine Model	Cursor 8	Cursor 13	D9	TAMD103A*	D12
Cylinders	6	6	6	6	6
Displacement - L	7.8	12.9	9.4	9.6	12.1
Bore x Stroke - mm	115 x 125	135 x 150	120 x 138	121 x 140	131 x 150
Compression Ratio	16.0:1	16.0:1	17.4:1	17.0:1	16.5:1
Aspiration	Turbo & Aftercooled	Turbo & Aftercooled	Turbo & Aftercooled	Turbo & Aftercooled	Turbo & Aftercooled
Injection Control	Electronic	Electronic	Electronic		Electronic
Rated Power - hp	543	760	575	390	715
Rated Speed - RPM	2600	2300	2500	1800	2300
Power-to-Weight Ratio - hp/lbs	0.271	0.250	0.243	0.149	0.232
Length - mm	1243	1465	1310	1416	1950
Width - mm	855	1088	858	900	1027
Height - mm	954	1040	1007	1143	1067
Weight - lbs	2006	3042	2370	2623	3086

\*This engine is not rated for this duty rating.  
The rating provided is from the next rating down, Light Duty (C).

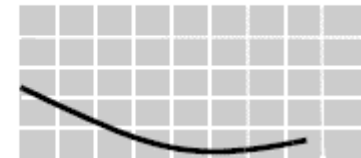
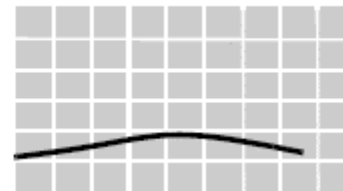
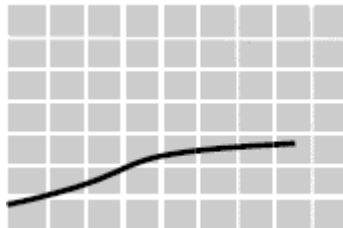

# Cursor vs. Yanmar – A<sub>1</sub> Rating

Manufacturer	Iveco	Iveco	Yanmar	Yanmar
Engine Model	Cursor 8	Cursor 13	CX	6SY
Cylinders	6	6	6	6
Displacement - L	7.8	12.9	7.413	11.7
Bore x Stroke - mm	115 x 125	135 x 150	110 x 130	127 x 154
Compression Ratio	16.0:1	16.0:1		
Aspiration	Turbo & Aftercooled	Turbo & Aftercooled	Turbo & Aftercooled	Turbo & Aftercooled
Injection Control	Electronic	Electronic		
Rated Power - hp	543	760	500	720
Rated Speed - RPM	2600	2300	2900	2300
Power-to-Weight Ratio - hp/lbs	0.271	0.250	0.270	0.284
Length - mm	1243	1465	1504	1910
Width - mm	855	1088	824	870
Height - mm	954	1040	905	1038
Weight - lbs	2006	3042	1852	2536

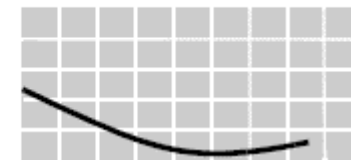
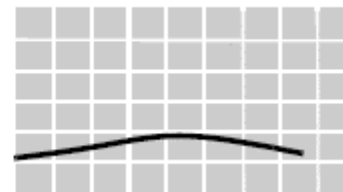
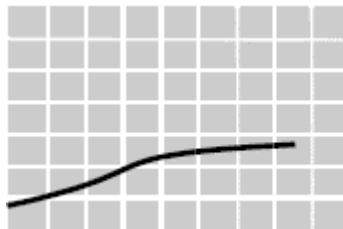

# Vector – A<sub>1</sub> Rating



V08 ENT M12 - “Vector 1200”

- First character indicates Vector
- Second & third digits indicate No. of Cyls. & displacement:  
08 → 8 cyls., 8 cyls. x 2.5L/cyl. = 20L
- Fourth letter denotes Electronic fuel injection
- Sixth character indicates Turbocharged-aftercooled
- Last two numbers show approximate power\*: 68 → 680mhp, 12 → 1200mhp

\*Horsepower rating varies with duty rating

## Vector – A<sub>1</sub> Rating

---

Model	No. Cyl./Asp.	Disp. - L	hp @ RPM
V08 ENT M12	V8 - TAA	20.08	1184 @ 2300

## Vector Competitors – A<sub>1</sub> Rating

---

Suitable replacement for:

- Caterpillar C18 marine engines
- Cummins 19L marine engines
- Detroit Diesel / MTU 2000 Series
- Volvo 24.5L marine engines

The 20L Vector fits into a gap in the market between a variety of 18L and 24L engines from the competition. This makes it somewhat difficult to draw straight comparisons between Vector and the competition, but it also leaves Vector poised to capitalize on a potential niche. Also, Vector features high performance duty ratings in a class that typically is skewed heavily toward the commercial market.

Additionally, Vector still maintains the typical Iveco power-to-weight advantage over the competition.

# Vector vs. Caterpillar – A<sub>1</sub> Rating

Manufacturer	Iveco	Caterpillar
Engine Model	<b>Vector 8</b>	C18
Cylinders	V8	V8
Displacement - L	20.0	18.0
Bore x Stroke - mm	145 x 152	145 x 183
Compression Ratio	15.4:1	
Aspiration	Turbo & Aftercooled	Turbo & Aftercooled
Injection Control	Electronic	Electronic
Rated Power - hp	1184	1001
Rated Speed - RPM	2300	2300
Power-to-Weight Ratio - hp/lbs	0.283	0.264
Length - mm	1900	1558
Width - mm	1220	1056
Height - mm	1201	1178
Weight - lbs	4189	3788

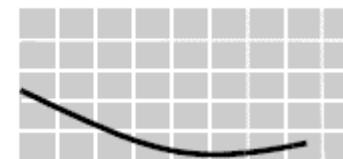
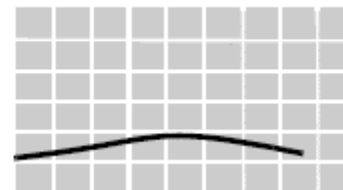
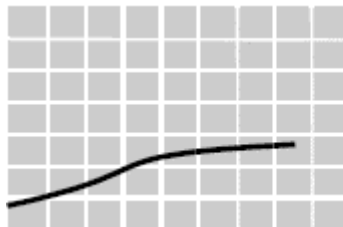

# Vector vs. Cummins – A<sub>1</sub> Rating

Manufacturer	Iveco	Cummins
Engine Model	<b>Vector 8</b>	QSK*
Cylinders	V8	6
Displacement - L	20.0	19.0
Bore x Stroke - mm	145 x 152	159 x 159
Compression Ratio	15.4:1	15.0:1
Aspiration	Turbo & Aftercooled	Turbo & Aftercooled
Injection Control	Electronic	Electronic
Rated Power - hp	1184	800
Rated Speed - RPM	2300	2100
Power-to-Weight Ratio - hp/lbs	0.283	0.142
Length - mm	1900	1792
Width - mm	1220	1065
Height - mm	1201	1647
Weight - lbs	4189	5623

\*This engine is not rated for this duty rating.  
The rating provided is from the next rating down, Light Duty (C).

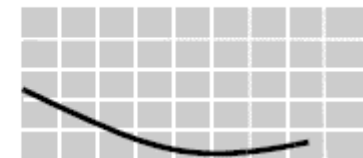
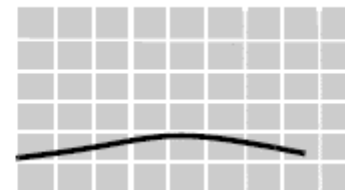
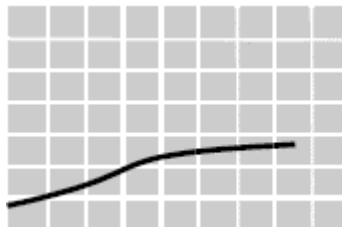

# Vector vs. Detroit Diesel / MTU – A<sub>1</sub> Rating

Manufacturer	Iveco	Detroit Diesel / MTU	Detroit Diesel / MTU
Engine Model	Vector 8	Series 2000	Series 2000
Cylinders	V8	V8	V12
Displacement - L	20.0	15.9	23.9
Bore x Stroke - mm	145 x 152	130 x 150	130 x 150
Compression Ratio	15.4:1		13.5:1
Aspiration	Turbo & Aftercooled	Turbo & Aftercooled	Turbo & Aftercooled
Injection Control	Electronic	Electronic	Electronic
Rated Power - hp	1184	900	1500
Rated Speed - RPM	2300	2300	2350
Power-to-Weight Ratio - hp/lbs	0.283	0.234	0.266
Length - mm	1900	1884	2327
Width - mm	1220	1274	1349
Height - mm	1201	1144	1222
Weight - lbs	4189	3850	5640

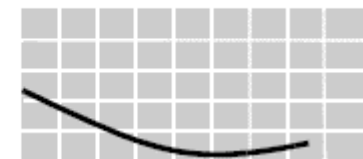
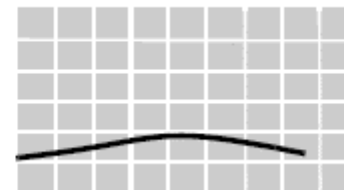
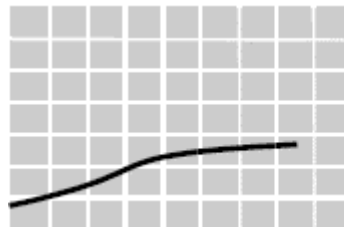

# Vector vs. Volvo – A<sub>1</sub> Rating

Manufacturer	Iveco	Volvo
Engine Model	<b>Vector 8</b>	D25*
Cylinders	V8	6
Displacement - L	20.0	24.5
Bore x Stroke - mm	145 x 152	170 x 180
Compression Ratio	15.4:1	14.0:1
Aspiration	Turbo & Aftercooled	Turbo & Aftercooled
Injection Control	Electronic	
Rated Power - hp	1184	823
Rated Speed - RPM	2300	1800
Power-to-Weight Ratio - hp/lbs	0.283	0.124
Length - mm	1900	2173
Width - mm	1220	1233
Height - mm	1201	1615
Weight - lbs	4189	6614

\*This engine is not rated for this duty rating.  
The rating provided is from the next rating down,  
Medium Duty (B).

