

INSTALLATION INSTRUCTION

C78 ENT M50

MARINE ENGINE

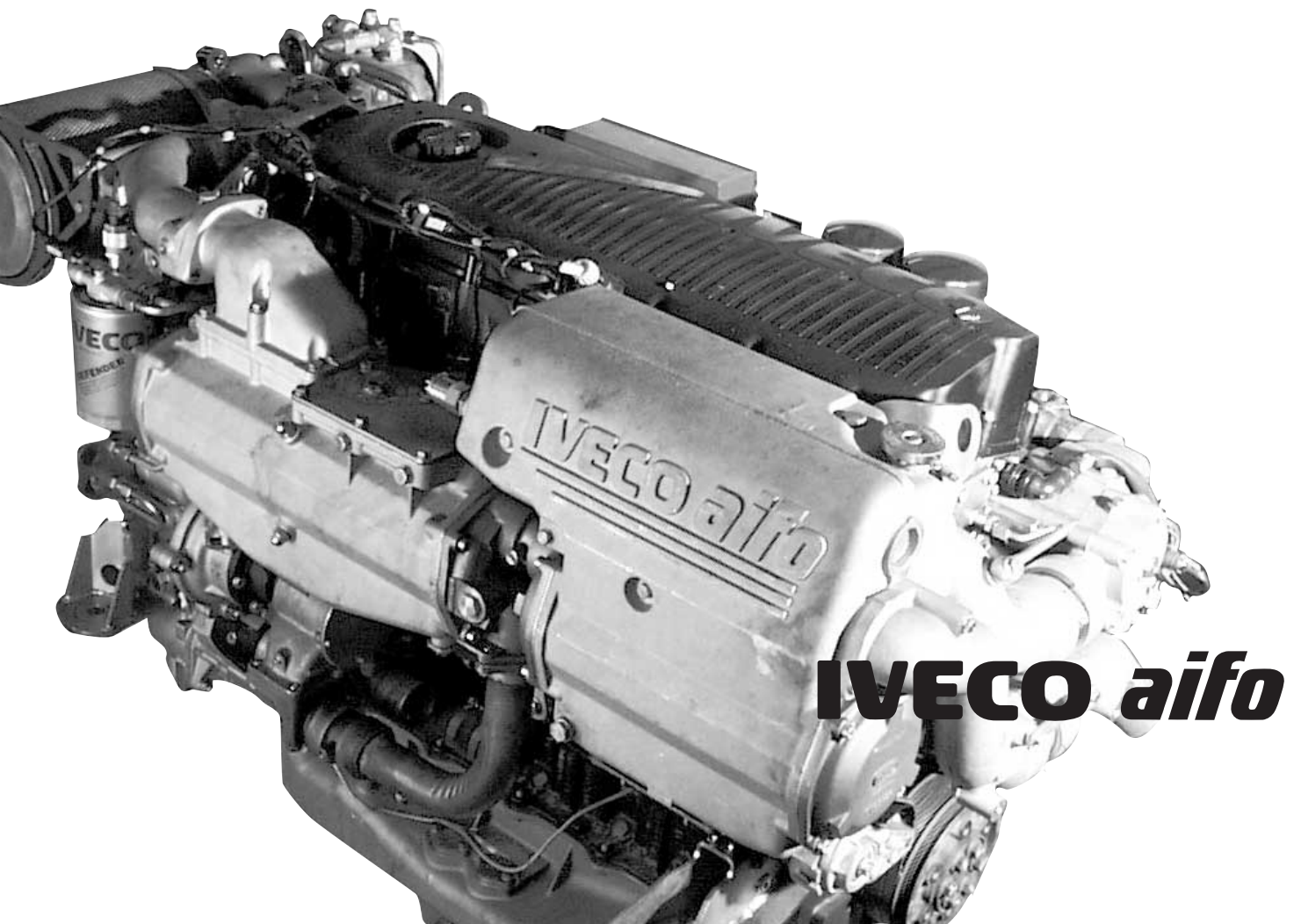

IVECO *aifo*

FOREWORD

Please read carefully the indications provided in this document: compliance with them will ensure the engine will continue to run smoothly and reliably, protecting users and service personnel against the risk of mishaps.

The instructions contained in this document pertain specifically to the C78 ENT M50 engine and complement the IVECO Aifo publication "Marine Engine Installation Manual", which should be referred to for all matters not covered herein.

Any installation not in compliance with the contents of these instructions, or modifications to the engine and its fittings are not admitted. The installing Yard is required to conduct tests to verify the functional compatibility between the engine's electrical-electronic equipment and the other electronic devices present on the boat.

Engineers and installation personnel are reminded of their obligation to comply with workplace safety rules.

To ready the engine for starting, follow the procedure set out at the end of Section 2 of this document.

To get the best possible performance out of the engine, it is mandatory to conform with its intended mission profile. The engine must not be used for purposes other than those stated by the manufacturer. IVECO Aifo is willing to examine beforehand any requirements for particular installations.

In particular

- Use of unsuitable fuels and oils may compromise the engine's regular operation, reducing its performance, reliability and working life.
- For the engine to maintain its original condition, it is absolutely mandatory to use only Original IVECO Parts.
- Any tampering, modifications, or use of non-original parts may jeopardize the safety of service personnel and boat users.

Spares may be supplied only if the following are indicated:

- Commercial code and serial number of the engine;
- Part number as per spares catalog.

The information provided below refers to engine features as of the date of publication. The manufacturer reserves the right to make modifications at any time and without advance notice, to meet technical or commercial requirements or to comply with local legal and regulatory requirements.

**The manufacturer
is not liable for any errors
or omissions.**

The IVECO competence and professionalism of the Customer Service Network is always available to our customers.

Publication Edited by:
IVECO Engine Business Unit
C.O. Mkt. Advertising & Promotion
IVECO Aifo – Pregnana Milanese

Printed **L 320.34.011** - Ed. 02/03

SECTION CONTENTS

OVERVIEW	1
INSTALLATION INSTRUCTIONS	2
DIAGNOSTICS	3

SECTION I**Overview**

	Pagina
IDENTIFYING DATA	3
<input type="checkbox"/> Product model number	4
<input type="checkbox"/> Commercial code	5
ENGINE COMPONENTS	6
PERFORMANCE	8
GENERAL SPECIFICATIONS	10

IDENTIFYING DATA

Figure 1/1

Ist version tag

IVECO aifo S. p. A. Viale dell' Industria, 15/17 20010 Pregnana Milanese MI - Italy	
1	MODELLO <input type="text" value="F2BE0686A*A001"/>
2	N° IDENTIFICAZIONE <input type="text" value="8032920"/>
3	MATRICOLA <input type="text"/>
4	SGLA COMMERC. / VERSIONE <input type="text" value="C78ENT.M50"/> <input type="text" value=".10"/>
Industrial & Marine engine	

Figure 1/2

IInd version tag

IVECO aifo S. p. A. Viale dell' Industria, 15/17 - 20010 Pregnana Milanese MI - ITALY	
4	ENGINE TYPE <input type="text" value="C78ENTM50"/>
DATA SET REF. <input type="text"/>	
3	ENGINE S/N <input type="text" value="000000"/> ENGINE DRW <input type="text"/>
OMOLOGATION <input type="text"/> N° <input type="text"/>	
COMMERC. TYPE / VERSION <input type="text"/> <input type="text" value=".10"/>	
Industrial & Marine engine	

1. Model number - 2. - Drawing number - 3. Serial number - 4. Commercial code



Figure 2

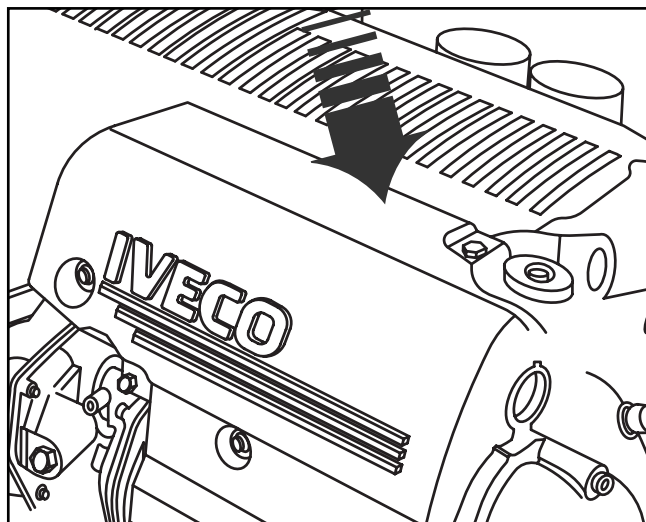

The engine's Model Number and identifying data are stenciled on a tag located on the engine coolant tank.

PRODUCT MODEL NUMBER

The model number is assigned by the manufacturer: it is used to identify the main characteristics of the engine, and to characterize its application and power output level. This number is stenciled on 1st version tag and always stamped on a side of crank-case.

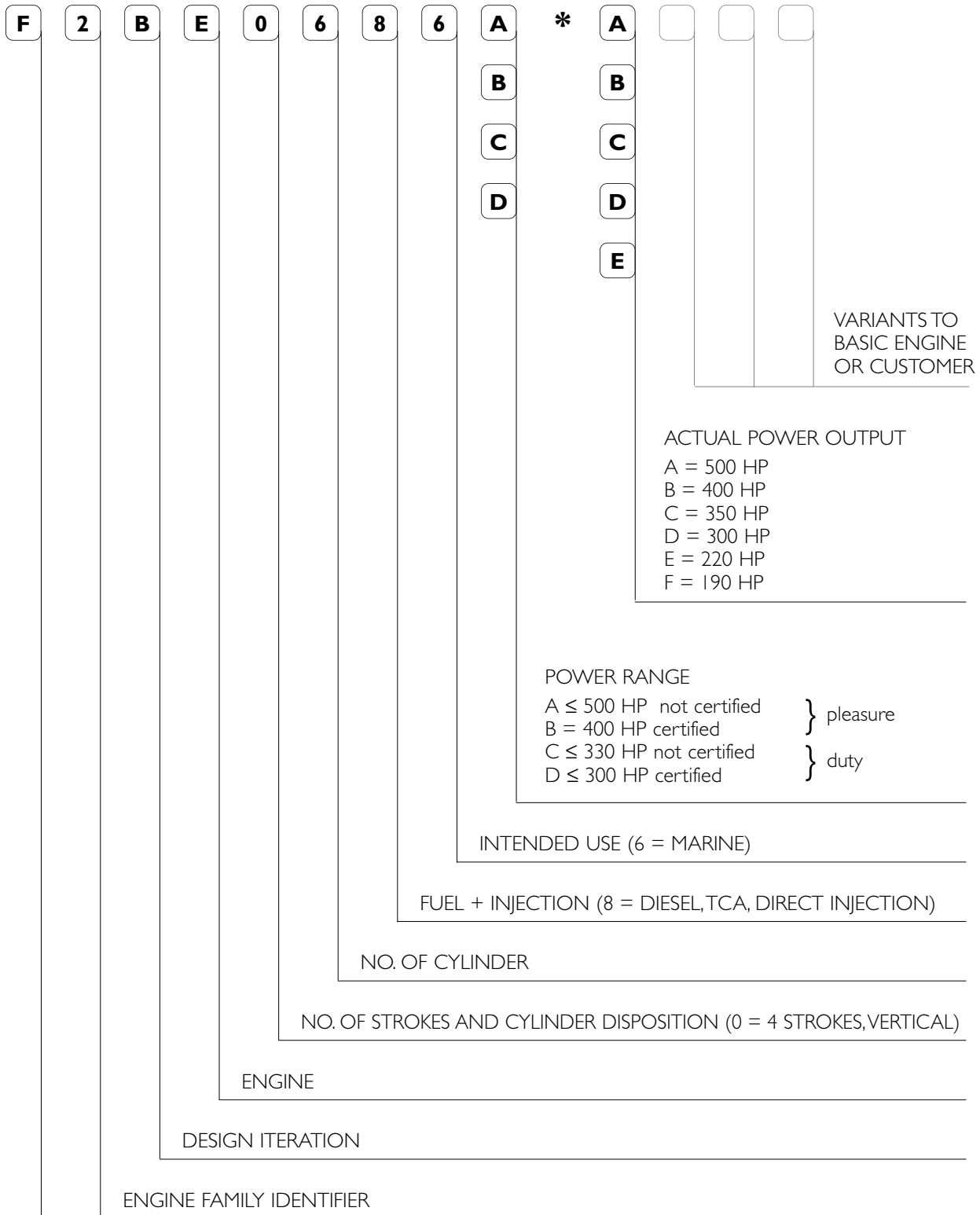

COMMERCIAL CODE

The purpose of the commercial code is to make it easier to understand the characteristics of the product, categorizing the engines according to their family, origins and intended application. The commercial code, therefore, cannot be used for technical purposes to recognize the engine's components: this purpose is served by the model number.

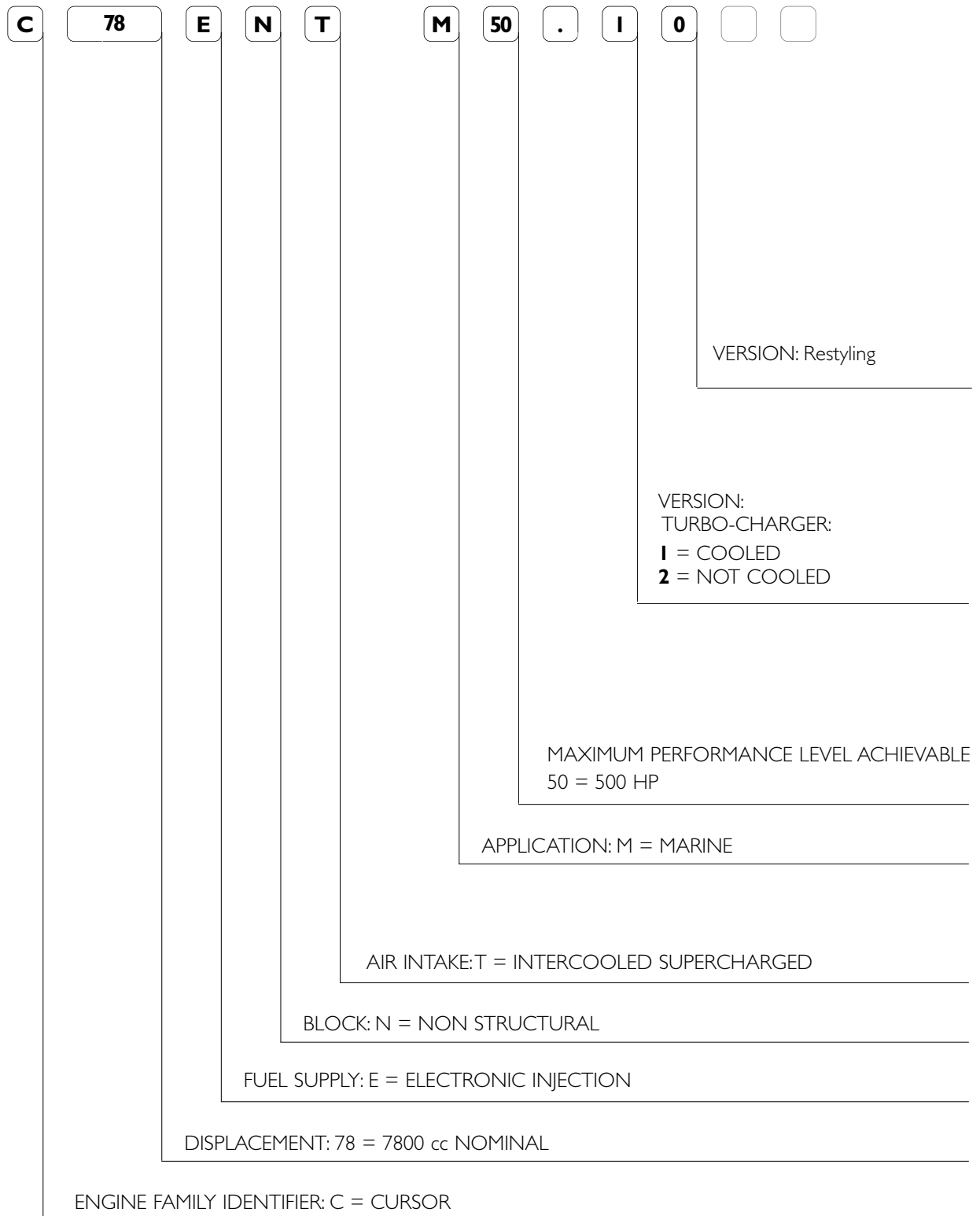

C78 ENT M50 ENGINE COMPONENTS

Figure 3

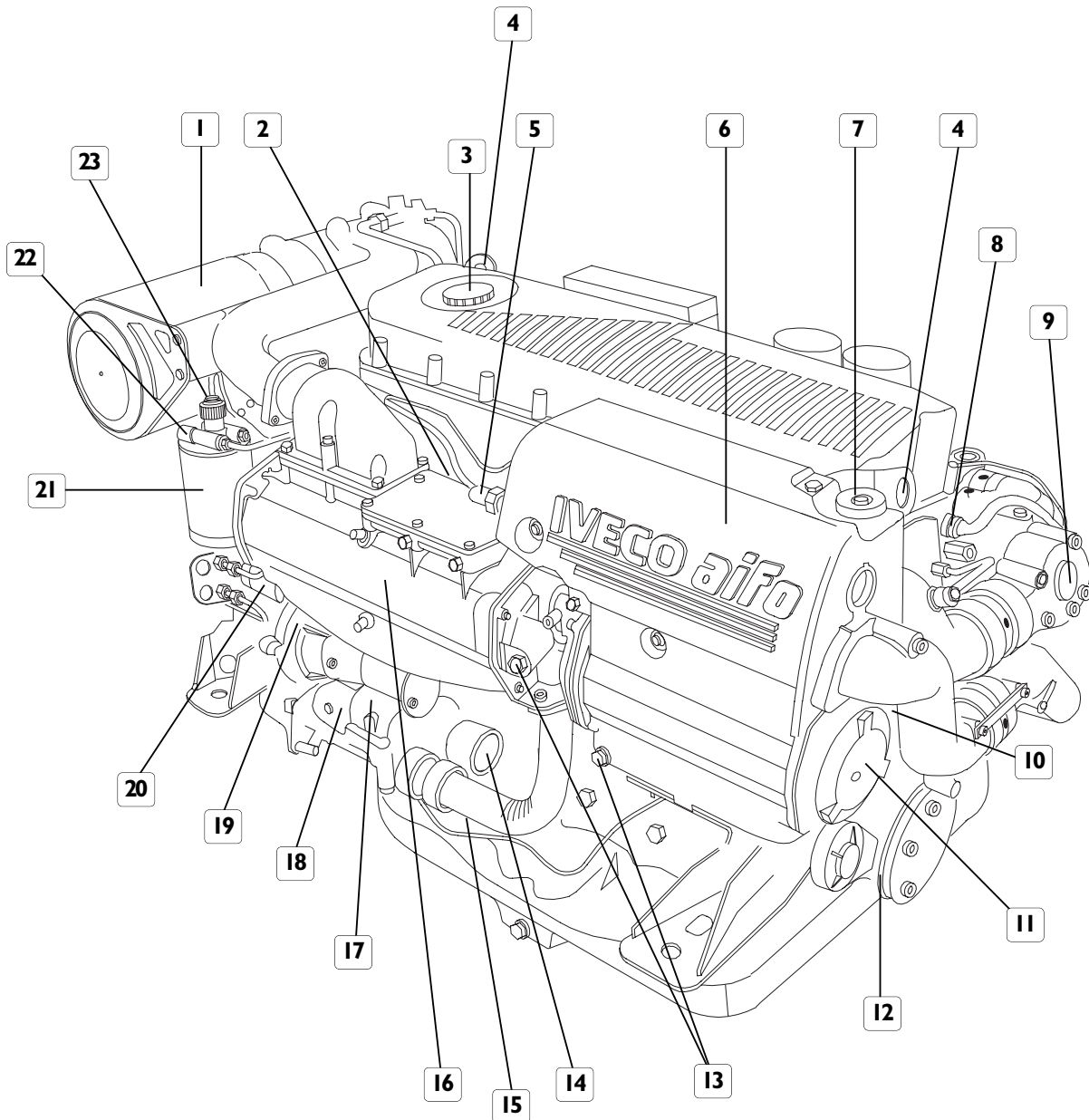

1. Intake air filter - 2. Intake air pressure and temperature sensor - 3. Lubricating oil refill cap - 4. Lifting padeyes - 5. Coolant level sensor - 6. Coolant tank - 7. Coolant refill cap - 8. Injector solenoid valve connector - 9. Coolant thermostatic valve - 10. Alternator location - 11. Coolant-sea water tube bundle heat exchanger - 12. Auxiliary pulley - 13. Sacrificial anodes - 14. Sea water intake - 15. Sea water drain plug - 16. Air-sea water heat exchanger - 17. Sea water pump - 18. Electrical starter motor - 19. Sea water pump gear - 20. Fuel transfer pump - 21. Fuel filter - 22. Filter clogging sensor - 23. Fuel temperature sensor.

C78 ENT M50 ENGINE COMPONENTS

Figure 4

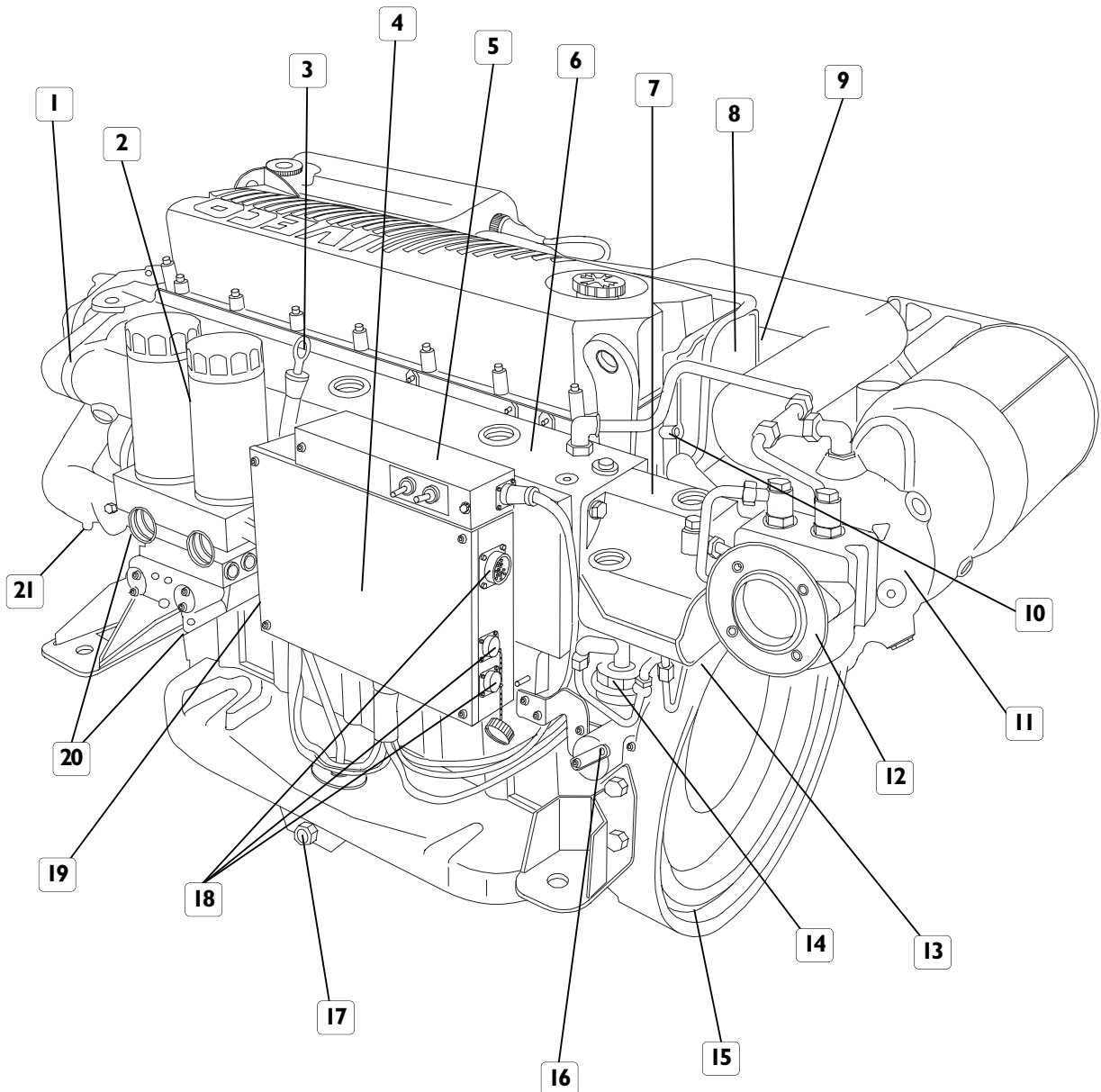

1. Coolant feed to exhaust manifold - 2. Lubricating oil filters - 3. Lubricating oil dipstick - 4. Electronic Management Box
 5. Lubricating oil intake-exhaust control unit - 6. Cooled exhaust manifold - 7. Turbocharger inlet pipe-fitting - 8. Timing mechanism and oil vapor filter cover - 9. Location of timing phase sensor - 10. Oil filter clogging indicator - 11. Cooled turbo-charger - 12. Exhaust gas manifold - 13. Phase and engine shaft rotation sensor location - 14. Waste-gate actuator
 15. Timing phase inspection port - 16. Throttle position sensor potentiometer - 17. Oil drain sump plug - 18. Instrument panel, diagnostics and EMB power supply wiring connectors - 19. Location of electrical pump and oil and pre-lubrication intake/exhaust solenoid valve - 20. Location of lubricating oil temperature and pressure sensors - 21. Coolant drain plug.

PERFORMANCE

Brake horsepower values in accordance with ISO 3046-1, attainable after about 50 hours of operation under reference environmental conditions characterized by 750 mmHg, 25°C, 30% relative humidity. Values fall within a tolerance of 5%.

Short range pleasure service (A1)

Type of boat

Pleasure and military boats with planing hull for high speed or semi-planing and displacing pleasure hulls that use maximum power for short periods alternating with prolonged periods at lower than maximum speed.

Engine utilization

Use of maximum power limited to 10% of the time. Cruising speed at engine rpm < 90% of nominal calibration rpm. Operating limit: 300 hours/year. Definition of calibrations and operating limits for military and government agencies according to contractual specifications.

Nominal maximum power	kW (HP) @ rpm	368 (500) @ 2600
Nominal maximum torque	Nm (kgm) @ rpm	1500 (153) @ 1600÷2200

Long range pleasure service (A2)

Type of boat

Pleasure and military boats with planing hull for high speed or semi-planing and displacing pleasure hulls that use maximum power for short periods alternating with prolonged periods at lower than maximum speed.

Engine utilization

Use of maximum power limited to 10% of the time. Cruising speed at engine rpm < 90% of nominal calibration rpm. Operating limit: 1000 hours/year. Definition of calibrations and operating limits for military and government agencies according to contractual specifications.

Nominal maximum power	kW (HP) @ rpm	330 (450) @ 2600
Nominal maximum torque	Nm (kgm) @ rpm	-

Light service (B)

Type of boat

Light boats for tourism, professional, or military use, with frequent speed changes. E.g.: pleasure boats, chartering, light passenger boats, high speed patrol boats for police, emergency, rescue, and special operations uses.

Engine utilization

Use of maximum power limited to 10% of the time. Cruising speed at engine rpm < 90% of nominal calibration rpm. Operating limit: 1,000 hours/year. Definition of calibrations and operating limits for military and government agencies according to contractual specifications.

Nominal maximum power	kW (HP) @ rpm	294 (400) @ 2600
Nominal maximum torque	Nm (kgm) @ rpm	1400 (143) @ 1600÷1800

Intermediate service (C)

Type of boat

Light boats for commercial, military, work and light fishing uses with variable speed. E.g.: patrol boats, pilot boats, light fishing vessels, water taxis, medium range seasonal passenger transport, fire-fighting.

Engine utilization

Use of maximum power limited to 25% of the time. Cruising speed at engine rpm < 90% of nominal calibration rpm. Operating limit: 1,000 ÷ 3,000 hours/year. Definition of calibrations and operating limits for military and government agencies according to contractual specifications.

Nominal maximum power	kW (HP) @ rpm	258 (350) @2600
Nominal maximum torque	Nm (kgm) @ rpm	1180 (120) @1600÷2200

Fuel economy – Pleasure use (A1)

Specific fuel consumption at maximum power	g/kWh (g/HPh) @ rpm	≤ 218 (≤ 160) @ 2600
Specific fuel consumption at maximum torque	g/kWh (g/HPh) @ rpm	≤ 200 (≤ 147) @ 1800
Lubricating oil consumption at maximum power	g/h @ rpm	≤ 240 @ 2600

Gas Emissions

Compliance with Standard	IMO MARPOL 73/78 ADDENDUM DIR. 94/25/EC
--------------------------	--

Sound Emissions

Maximum value of average level for engines in basic configuration	dB@A (measurement standard)	95 (ISO 3744)
--	-----------------------------	---------------

Power Takeoffs (Optional)

3- throated Front Pulley for V belts

Basic diameter	mm	202
Throat size	mm	10
Power available to each belt	kW (HP)	≤ 7,4 (≤ 10)

3-throated Front Pulley + Elastic Joint for Flange Coupling

Available torque	Nm (kgm)	≤ 500 (≤ 51)
------------------	----------	--------------

3-throated Front Pulley + Elastic Joint for Shaft Coupling

Available torque	Nm (kgm)	≤ 400 (≤ 40,8)
------------------	----------	----------------

GENERAL SPECIFICATIONS

Model	C 78 ENT M50	
Cycle	4-Stroke Diesel	
Charge	Supercharged and intercooled	
Injection	Direct	
Number of cylinders	6 in line	
Bore	mm	115
Stroke	mm	125
Total displacement	cm ³	7790
Compression ratio	16 ± 0,8 : 1	
Direction of rotation, flywheel side	counterclockwise	
Minimum idling rpm	rpm	600 ± 25
Maximum engine rpm, no load	rpm	2800 ± 25

Engine inclination in continuous operation

Maximum longitudinal angle (static) min / max	degrees/360	+ 4 / + 10
Maximum longitudinal angle (static + dynamic)	degrees/360	+ 20
Maximum transverse angle (static + dynamic)	degrees/360	± 22,5
Oil dipstick valid for static inclination	degrees/360	± 10

Supercharge

Turbo-charger with water-cooled body	KKK K31	
Pressure regulation	with waste-gate	
Waste-gate maximum opening pressure	bar	2,5 ± 0,1

Lubrication

Oil	type	SAE 15 W40/E 3
Oil compliant with specifications	ACEA E3 / API CF4 / MIL L2104E/F	
Total oil capacity on first filling	liters (kg)	31 (28)
Total oil capacity with sump at minimum level	liters (kg)	18 (16,3)
Total oil capacity with sump at top level	liters (kg)	25 (22,7)
Oil pressure, warm engine, minimum idling rpm	bar	≥ 1,5
Oil pressure, warm engine, maximum rpm	bar	≥ 5
Maximum allowed temperature	°C	105
Oil dipstick valid for static inclination	degrees/360	± 10

Fuel supply

Fuel oil compliant with standard	EN 590	
Low pressure transfer pump	gear pump	
Flow rate at maximum rpm	kg/h	88
Fuel return flow rate to tank	kg/h	≤ 12
Filtering: pre filter	µm	36,5
Filtering: filter	µm	5

Injection system

Type	pump - injectors (PDE)	
System	Bosch EDC MS 6.2	
Maximum injection pressure	bar	1600

Low temperature starting

Allowed, without external aids, down to	°C	-15
With electrical heating of intake air (optional), down to	°C	-25
With additional external heater, down to	°C	-30

Cooling

Closed coolant loop with sea water heat exchanger	50% mixture of water/Paraflu II or equiv. Compliant with SAE J 1034 specification	
Total coolant quantity	liters	~ 40
Engine-only capacity	liters	~ 15,5
Expansion tank	standard	
Forced circulation	centrifugal pump	
Flow rate at maximum rpm	l/h	25200
Temperature regulation	with thermostatic valve	
Initial opening	°C	68 ± 2
Maximum opening	°C	78 ± 2
Sea water line	forced circulation	
Self-priming pump	with neoprene impeller	
Sea water pump height above sea level	m	≤ 2
Max. pump capacity	l/h	17500

Exhaust gas expulsion

Optional	stack
Optional	riser

Electrical system

Nominal voltage	V dc	24
Self-regulated alternator: voltage	V dc	29
maximum current intensity	A	90
Electrical starter motor: nominal voltage	V dc	24
absorbed electrical power	W	4500
Recommended batteries capacity	Ah	≥ 120
Current discharge at - 18 °C (SAE J 537)	A	≥ 900

Drive train coupling

Flywheel diameter	mm (inches)	355 (14)
Flywheel case	type	SAE I

Weights

Dry without inverter	Kg	900
----------------------	----	-----

Figure 5

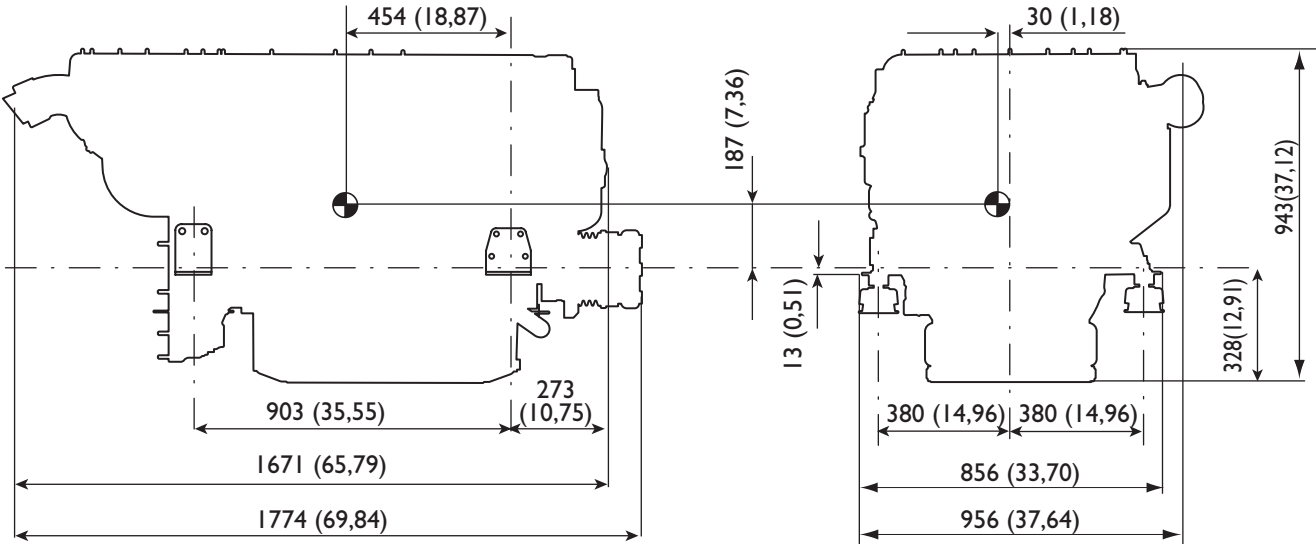

⊕ Centre of gravity

mm (inches)

SECTION 2

Installation Instructions

	Page
INSTALLATION OVERVIEW	3
CAUTIONS	4
<input type="checkbox"/> Handling cautions	4
<input type="checkbox"/> Installation cautions	4
<input type="checkbox"/> Engine's first start	4
<input type="checkbox"/> Use and servicing cautions	4
<input type="checkbox"/> Prolonged engine inactivity	4
DESIGN STANDARDS	5
<input type="checkbox"/> Accessibility	5
<input type="checkbox"/> Securing	5
<input type="checkbox"/> Engine intake and ventilation air	5
<input type="checkbox"/> Sea water pipeline	5
<input type="checkbox"/> Engine pre-heating	5
<input type="checkbox"/> Exhaust gas	5
<input type="checkbox"/> Starting aid	5
TECHNICAL DATA FOR INSTALLATION	6
FUEL LINE	7
<input type="checkbox"/> Prefilter	7
<input type="checkbox"/> Material characteristics	7
ELECTRICAL CIRCUIT	8
<input type="checkbox"/> EMB	8
<input type="checkbox"/> Power grid	10
<input type="checkbox"/> Engine electrical ground	10
<input type="checkbox"/> Battery recharge	11
<input type="checkbox"/> Instrument and control panel	11
<input type="checkbox"/> Instrument panel connection cable	11
<input type="checkbox"/> Throttle position sensor	11
INSTALLATION TESTS	12
<input type="checkbox"/> Lubricating oil fill	12
<input type="checkbox"/> Fuel tank suction	12
<input type="checkbox"/> Throttle position sensor	12
<input type="checkbox"/> Pre-lubrication	12

Page

<input type="checkbox"/> First start	13
<input type="checkbox"/> Fuel pressure in fuel supply line	14
<input type="checkbox"/> Indication and control panel	14
<input type="checkbox"/> EMB Electrical power supply	14
<input type="checkbox"/> ECU temperature	14
<input type="checkbox"/> Engine compartment vacuum	14
<input type="checkbox"/> Engine compartment air temperature	14
<input type="checkbox"/> Fuel temperature	14
<input type="checkbox"/> Exhaust back-pressure	14
<input type="checkbox"/> Exhaust temperature	14
PANEL WIRING	15
PREVENTIVE MAINTENANCE IN CASE OF PROLONGED ENGINE INACTIVITY	16
ENGINE'S FIRST START / RESTORING NORMAL OPERATING CONDITIONS	16

INSTALLATION OVERVIEW

The figure shows the set of components of an installation including those supplied, as standard or optional items, with the engine equipment, and those supplied or built by the yard. The figure is meant to provide an overall picture of the operations required for engine installation. Component positions and illustrations are not binding, but merely provided by way of indication, and they depend on the choices made by yard engineers according to their competence, to the spaces and the prescriptions set out in the chapter that follows.

Figure 1

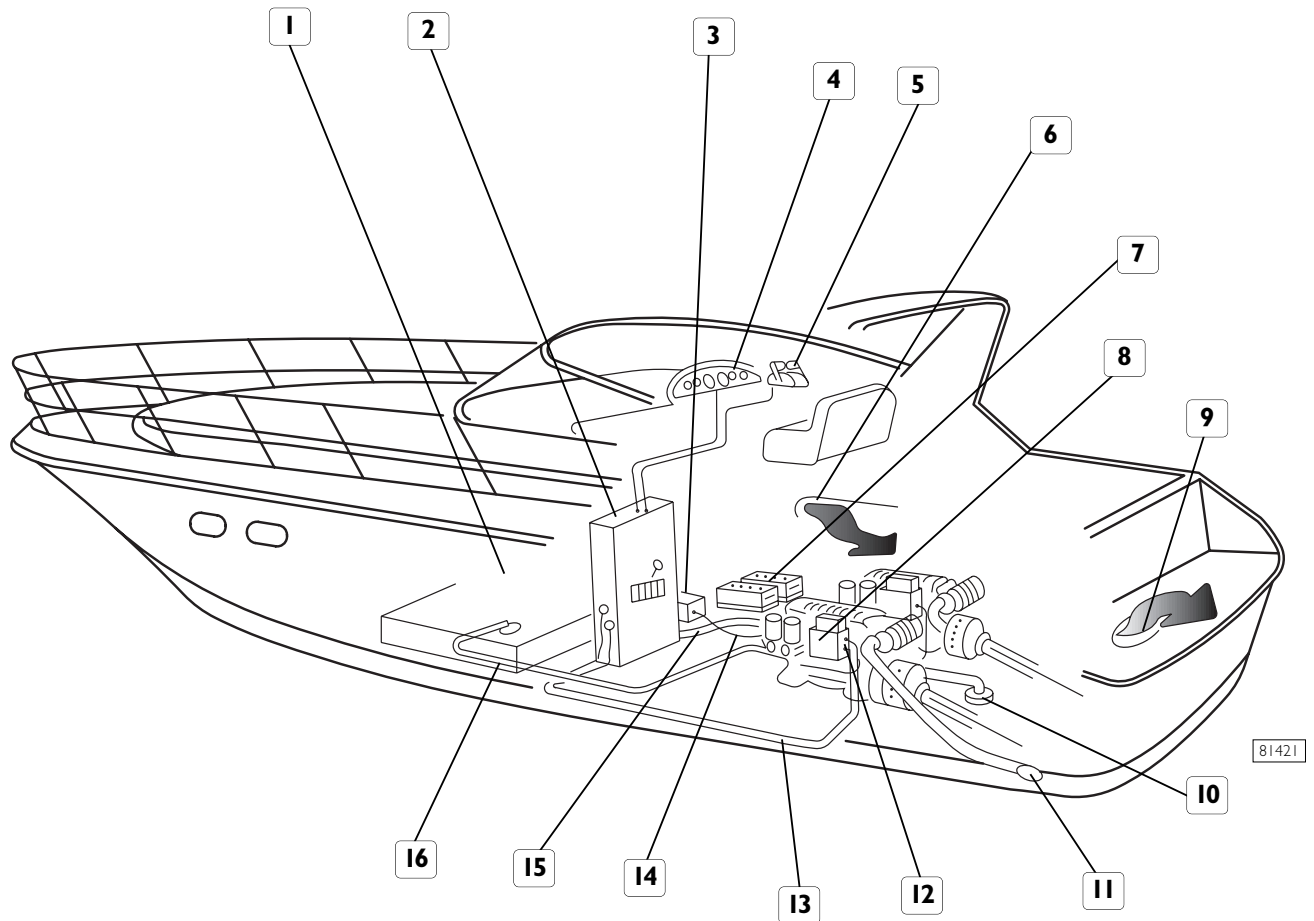

1. Fuel tank with suction/return assembly - 2. Electrical system cabinet - 3. Servo-throttle - 4. Instrument panel - 5. Throttle lever - 6. Engine and ventilation air intake - 7. Batteries - 8. Electronic Management Box (EMB) - 9. Ventilation air exhaust - 10. Sea water suction and decanting filter - 11. Exhaust gas and sea water drain pipe - 12. EMB power supply wiring - 13. Indication and control panel wiring - 14. Linkage for throttle potentiometer operation - 15. Power grid wiring from battery to generator/electrical starter motor - 16. Fuel tank feed and return pipe.

CAUTIONS

While an electronically controlled injection system provides for better engine performance, it also makes it mandatory for installing and servicing personnel to comply with some fundamental rules that will surely become the norm as electronic engine control equipment becomes ever more widespread.

Boat fitters and servicing personnel are invited to familiarize themselves with the notes that follow and to contact IVECO Aifo personnel whenever compliance should prove impossible.

Failure to comply with the rules set out below shall void the warranty and exonerate IVECO Aifo from all liabilities.

Handling

The engine shall be handled by experienced personnel, using the prescribed tool or an equalizer that will keep the lifting lines parallel and with suitable equipment in terms of load bearing capacity and size.

The two padeyes provided for lifting the engine alone shall always be used simultaneously.

Installation

- Use of switches or battery disconnects on the EMB power supply line is not allowed.
- Do not modify wiring; wire length cannot be changed.
- Use only electronic device wiring compliant with the IVECO standard, in terms of length, conductor type, location, clamping, shielding and grounding braids connection.
- To avoid any interference, the wiring for devices other than engine electronic systems must follow different paths.
- Do not connect any extraneous device to the engine electrical equipment.
- Do not provide electrical voltage to the boat's system before first verifying that there are no short circuits.
- Do not insert pipes for drawing fuel from the engine fuel supply pipelines.
- Do not make any modification to the engine's hydraulic circuits and components.
- Do not perform any electric arc welding operations without first removing the electronic units from the seat, placing them at a suitable distance for safety.
- Do not subject electronic units to temperatures exceeding 80 °C.
- Do not paint electrical components and connections.
- Do not alter the data contained in the engine control unit.
- Tighten threaded elements according to the prescribed procedures and torque values.

Engine's first start

Follow the procedure set out in the paragraph entitled "Engine's first start / Restoring normal operating conditions" at the end of this section.

Use and servicing

- When starting the engine the first time, have available appropriate means to shut off engine air intake in case of runaway speed rate.
- Never disconnect the batteries electrically when the engine is running.
- Remove the batteries' electrical connections before any operation on the electrical system.
- Ensure that battery terminals comply with the correct polarity, that they are properly tightened and protected against any short circuits and corrosion phenomena.
- Do not connect or disconnect electrical connections on supplied circuits.
- Do not cause any sparks in the attempt to verify the presence of electrical voltage.
- Do not draw fuel from tanks made of copper alloys and/or with pipes lacking filtering systems.
- Do not wash the engine and its components with corrosive or abrasive detergents, to avoid jeopardizing the operating condition of the electrical connections.

Prolonged engine inactivity

The end of this section contains a list of the steps for preparing the engine before long inactivity periods, and for restoring it to its operating condition.

DESIGN STANDARDS

Accessibility

The engine shall be located in such a way as to allow to refill and drain engine fluids as required by servicing operations and to provide, even when underway, for easy access to electrical fuses and to the diagnostics push-buttons within the EMB.

Note that the lower part of the flywheel case has an inspection port, useful when phasing the engine references of the injection systems, and a window flanked with threaded holes, needed for fastening the "flywheel rotator" tool. If raised limber boards are installed in the engine room, these provisions may no longer be accessible to servicing personnel. In this case, the phasing operation can be carried out using a procedure that is typical of the marine application and described in the "OVERHAUL" section of the "Technical and Repair Manual"; use of the tool to rotate the flywheel, however, will be impossible.

Securing

Securing shall be accomplished by means of elastic blocks able to support the engine's mass and the longitudinal thrust exerted by the propeller shaft when in motion. Dimension and fastening information is provided in the "Installation Diagram".

Engine intake and ventilation Air

Compliance with prescriptions on the quantity of air necessary for combustion and ventilation assures regular engine operation even under adverse conditions and allows the engine to reach its maximum design power output. (1)

Sea water pipeline

It shall be provided with an inlet suitable for preventing extraneous bodies from entering the intake pipe. Between the inlet and the pump it is advisable to place a gate, to be closed in case of emergency or for extended stops, and a filter to hold the smaller impurities; it is also advisable to install a suitably sized, easily replaced zinc anode.

The engine sea water pipeline is fitted by the manufacturer with protective anodes to be replaced periodically (see "OVERVIEW" section).

The rubber hoses positioned along the pipeline shall be sufficiently rigid to avoid creating choke points due to pinching. (1)

Engine pre-heating

In case of usage requiring maximum power output immediately, installation of an auxiliary pre-heater on the closed cooling loop is recommended.

Exhaust gas

The exhaust fume discharge pipeline shall be positioned in compliance with the indications contained in the IVECO Aifo Publication "Marine Engine Installation Manual", which also provides indications to design the exhaust pipeline.

Starting aid

When the engine is to be used at temperatures lower than -15°C , an electrical grid heater is installed. Its operation is controlled by the electronic unit of the injection system. The element will be placed between the turbocharger and the air-water heater exchanger (after-cooler), replacing the terminal part of the intake duct. Connection to the electrical wiring provided is achieved interposing a specific relay and connection to the power supply grid.

For use at temperatures lower than -25°C , adoption of an auxiliary preheating system is recommended.

Figure 2

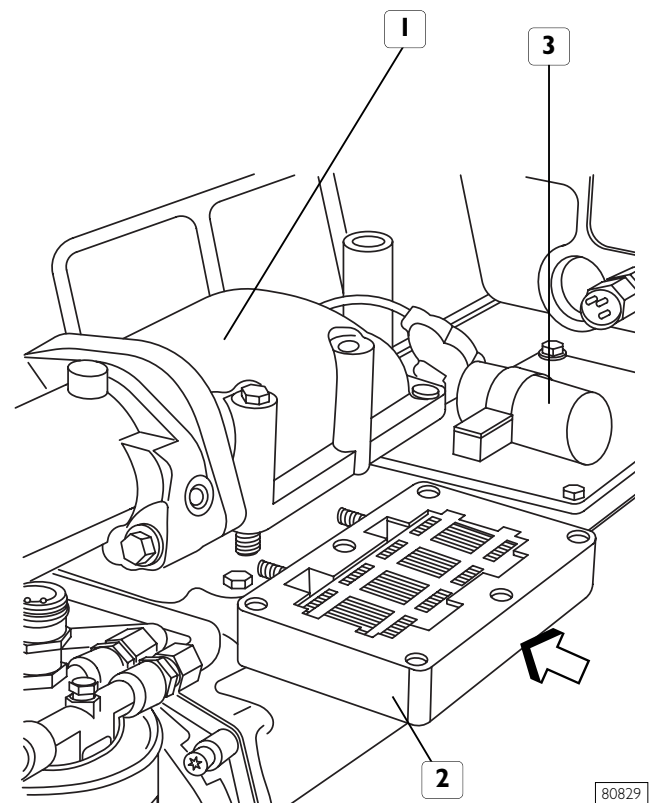

1. Specific junction pipe
2. Electrical grid heater
3. Power relay

(1) The EDC electronic engine control is programmed to reduce maximum power output whenever the operating parameters measured by the sensors indicate that critical conditions have been reached which, if exceeded, would lead to the risk of damaging the engine.

TECHNICAL DATA FOR INSTALLATION

Engine intake and ventilation air when underway

Static vacuum allowed downstream of the air filter	kPa mmH ₂ O	≤ 3 ≤ 300
Engine air intake flow rate	m ³ /h	≥ 1785
Engine room ventilation air flow rate	m ³ /h	≥ 9000
Static vacuum allowed in the engine room	kPa mmH ₂ O	≤ 0,1 ≤ 10
Temperature allowed in the engine room	°C	≤ 50

Exhaust gas discharge

Optimum static back pressure	kPa mmH ₂ O	≤ 7 ≤ 700
Allowed static back pressure	kPa mmH ₂ O	≤ 10 ≤ 1000
Temperature at maximum power	°C	480
Flow rate at maximum power	Kg/h	1900
Riser outer diameter	mm (inches)	153 (6)
Dry exhaust outer diameter	mm (inches)	114 (4,5)
Diameter of circumference of distance between 6 locking holes	mm (inches)	150 (5,9)

Fuel supply

Transfer pump delivery at maximum rpm	Kg/h	≤ 88
Flow rate return to tank	kg/h	≤ 12
Fuel temperature to allow maximum power	°C	≤ 78
Inner diameter, intake pipe	mm	8
Inner diameter, return pipe	mm	8
Thread on pre-filter junctions	M	14 × 1,5
Thread on engine junctions	inches UIC	1/2

Open sea water cooling line

Intake pipeline diameter	mm (inches)	60 (2,36)
Pump delivery at maximum rpm	l/h	17500
Sea water pump height above sea level	m	≤ 2
Allowed intake vacuum	kPa mmH ₂ O	20 2000
Discharge pipeline diameter	mm (inches)	50 (2)

Inverter oil heat exchanger

thread on engine junctions	inches UIC	1/2
----------------------------	------------	-----

Angle of inclination of the engine under continuous operation conditions

Longitudinal (static + dynamic)	degrees/360	≤ 25
Starboard side or port side (static + dynamic)	degrees/360	≤ 22,5

FUEL LINE

Figure 3

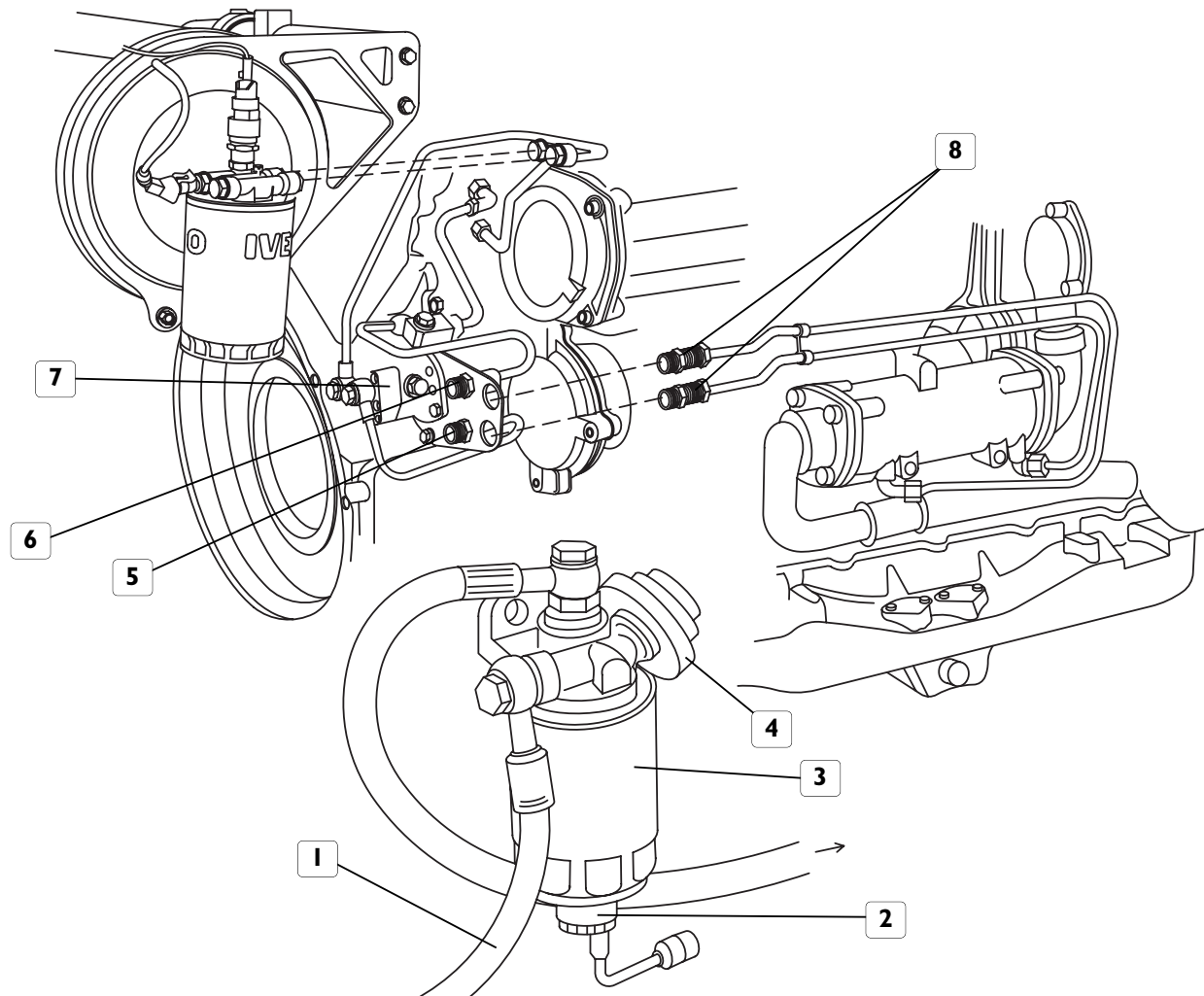

81795

1. From the tank - 2. Sensor for detecting the presence of water in the filter - 3. Decanting filter - 4. Priming pump - 5. Fuel inlet junction - 6. Fuel return junction to tank - 7. Gear pump - 8. Junctions for inverter oil heat exchanger.

Pre-filter

The pre-filter with priming pump, supplied separate from the engine, must be adequately fastened in such a way as to enable easily to replace the filtering cartridge and/or to operate the pump.

To avoid introducing impurities in the feeding pipelines inside the engine, we recommend not installing filtering cartridges previously filled with fuel in the system.

Material Characteristics

The fuel tank, the suction and return assembly and the feed pipes shall withstand the continuous abrasion caused by a 90 l/h flow of fuel oil at a temperature of 80 °C without noticeable warping, wear, or release of material.

Use of metallic materials, though not copper alloys, is allowed provided they are connected to the battery's negative terminal to avoid the accumulation of electrostatic dis-

charges. The tank shall be provided with a vent to prevent internal pressure from exceeding $\pm 5\text{kPa}$ ($\pm 0.5\text{ mmH}_2\text{O}$). Fuel tank and suction assembly shall be so shaped as to assure suction even at the maximum longitudinal and transverse inclination allowed for the boat, with a residual quantity of fuel oil considered "reserves".

It is recommended to obtain a residual capacity on the bottom of the tank, where the intake inlet should be positioned, and to use a Venturi inlet cup to prevent the entry of sludge. The return flow must take place in such a way as to favor the mixing of returning fuel oil with the fuel oil in the tank.

Use of metallic pipes, except those made of copper or its alloys, shall entail connecting each individual segment to the engine ground or battery negative terminal to prevent the accumulation of electrostatic discharges, and inserting a vibration damping elastic junction on each segment. Installed pipes shall be CE certified.

ELECTRICAL CIRCUIT

GENERAL NOTES

DO NOT USE wiring belonging to the engine's electrical equipment to supply power to other devices in the boat.

PLACE engine electrical wiring independently from the other wiring installed on the boat.

USE of switches or battery disconnects on the EMB power supply line is not allowed.

EXTREME CARE SHOULD BE PLACED in the polarization of the electrical connections and in the correct coupling of their locking elements.

EMB (Electronic Management Box)

This is the housing for the electrical and electronic units managing and controlling the engine's operation. It is supplied fastened to the engine in such a position as to allow for an easy access to the electrical components. If it is necessary to position it differently, fasten it in the vertical position with the wire bundles to the engine projecting downwards and at such a distance that no modifications to the engine wiring are required.

Electrically insulate the container, if secured to a metal bulk-head, to avoid the onset of parasite currents, and connect it to the negative terminal of the battery. The position must allow for easy access to the fuses and the diagnosing push-buttons contained in it, even when underway. No modification is allowed to the wiring.

Figure 4

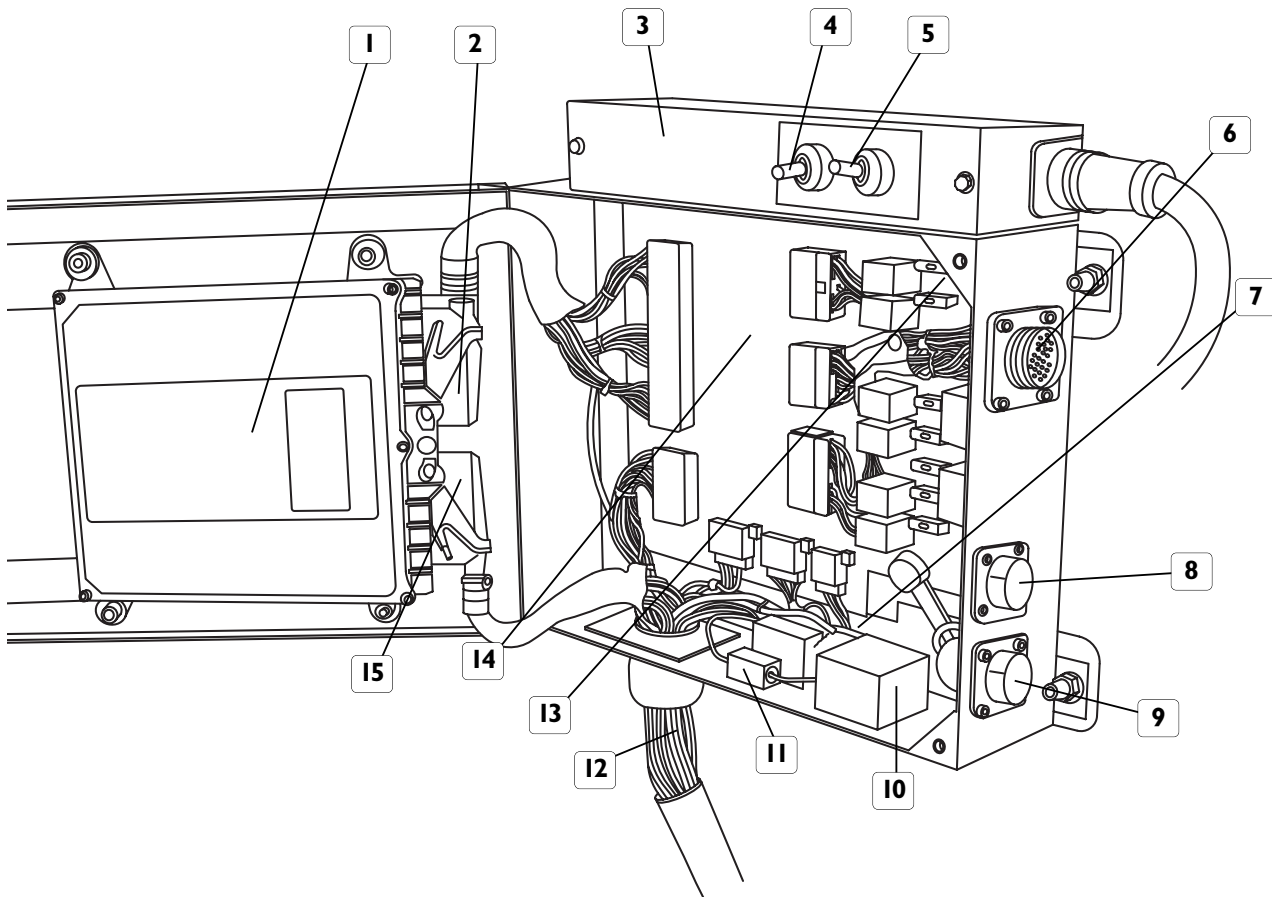

81422

1. EDC system electronic control unit - 2. ECU B connector - 3. Pre-lubrication control unit - 4. Electrical pre-lubrication pump intake/exhaust enabling control - 5. Pre-lubrication/engine oil replacement solenoid valve enabling control - 6. G connector for instrument panel wiring - 7. Fitting for negative polarity - electrical ground connections - 8. Q connector for diagnostic instrument connection - 9. H connector for power supply grid wiring - 10. Grid heater relay - 11. Alternator excitation resistor - 12. Engine electrical wiring and throttle potentiometer - 13. Location of blink-code push-button and indicator light - 14. Relay and fuse box - 15. ECU A connector.

Location of components on relay and fuse board

Figure 5

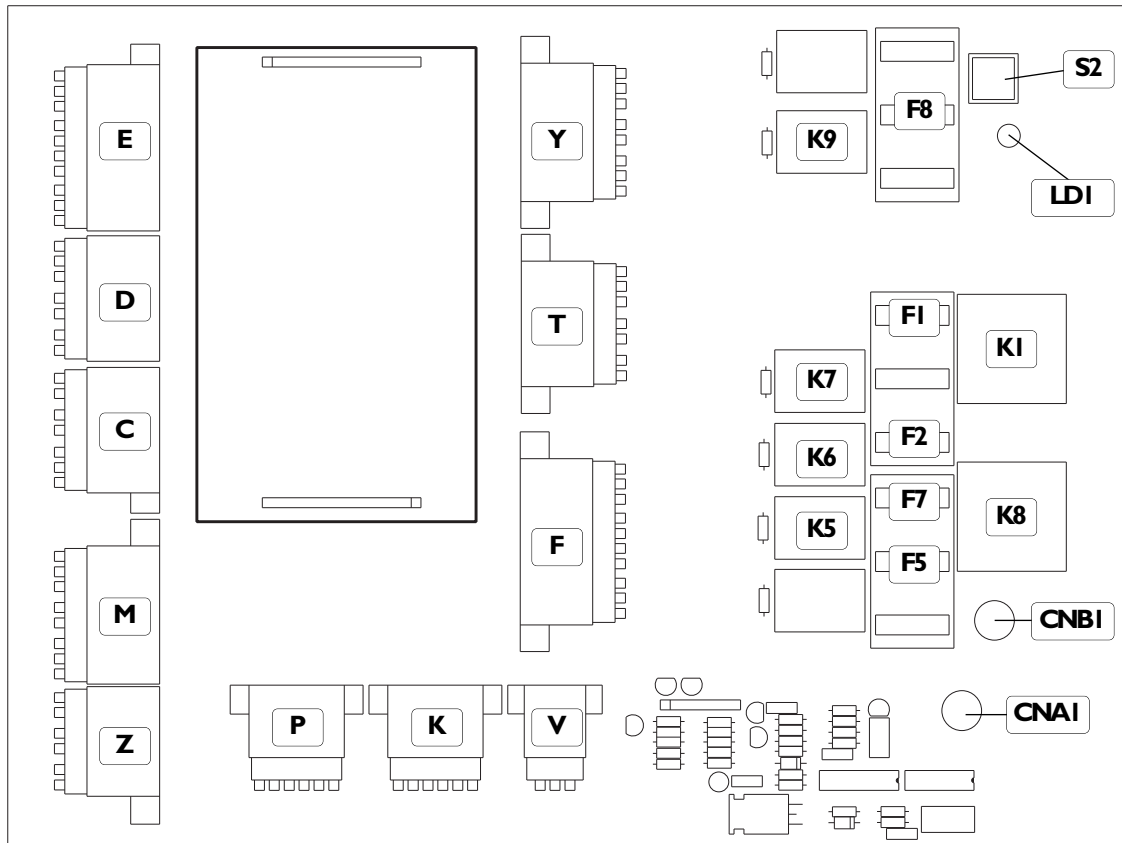

81423

Relays

K1	EDC main
K2	not used
K3	not used
K4	not used
K5	intercooler bypass control
K6	key switch discharge
K7	engine shut down
K8	starter control
K9	pre-lubricating oil pump control

Fuses

F1	EDC power supply
F2	alternator recharge indication circuit
F3	not used
F4	not used
F5	intercooler bypass
F6	not used
F7	master power supply
F8	electrical oil pump
F9	not used

E – D- C- M- Z- P- K- V- F- T –Y = wire / board electrical wiring connectors

CNAI = connection to battery's positive pole

CNBI = connection to terminal **50** of the electrical starter engine

PI = push-button for emission of EDC error codes

LDI = indicator light signaling the emission of EDC error codes

CAUTION

If magneto-thermal protection and intervention devices are interposed, they must not be used to shut the engine down or otherwise used just a few seconds after shutting the engine down.

Power grid

This provides electrical power to the EMB and the electrical starter motor and allows the alternator to recharge the batteries. The EMB is connected to the batteries by means of a wire bundle led to the H connector. The yard shall use conductors with a cross section of at least 6 mm² taking care to connect both conductors set to positive polarity to the + terminal of the battery.

Connection of the positive +30 of the electrical starter motor to the positive terminal of the battery allows to obtain, as shown in the figure, the simultaneous connection of the alternator.

To have a sufficient quantity of energy available when starting the engine, we recommend installing two series of dedicated batteries separately, the first for starting the engine and powering the injection system, the second one for on-board electrical machinery. The battery used to power the machinery may be recharged by interposing on the power supply line a relay commanded by the voltage of the alternator's electronic regulator recharge signal.

Engine electrical ground

The engine electrical connection is achieved by connecting, with a cable of suitable cross section, the negative terminal of the battery to the fastening point of the electrical starter motor as shown in Figure 8.

The grounding terminal is secured to the motor proceeding as follows:

- ❑ Completely remove the conducting paint or the old conducting paint from both parts constituting the connection, either with mechanical means or with a suitable chemical product; if parts whose surface has been treated need to be used for the securing operation, first completely remove the anaphoretic paint by mechanical means, obtaining a smooth support plane;
- ❑ Apply a uniform layer of the BH44D product (IVECO Standard 18-1705) with a brush or spray gun;
- ❑ Join the parts constituting the ground node within 5 minutes after applying the product.

Figure 6

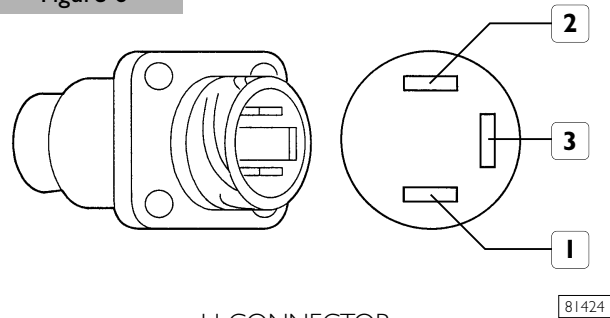

H CONNECTOR

1. EMB Power supply (positive) - 2. Grid heater power supply (positive) - 3. EMB power supply (negative).

Figure 7

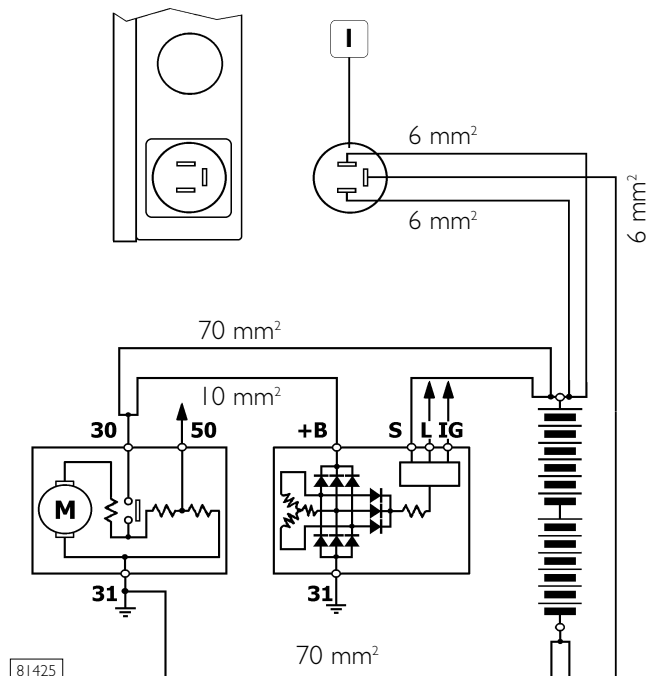

POWER GRID DIAGRAM

I. H Connector.

Figure 8

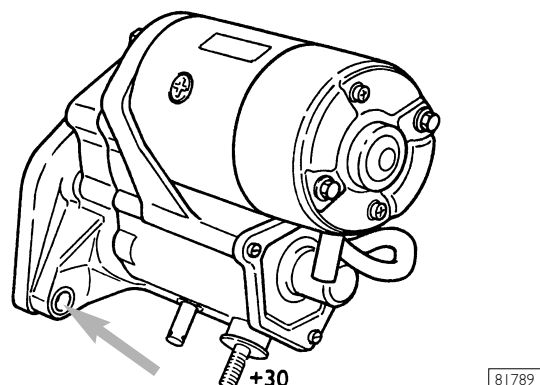

ENGINE ELECTRICAL GROUND CONNECTION POINT

Battery recharge

The electronic regulator of the alternator supplied with the engine can effectively control battery recharge through the **S** terminal of the three-pole connector.

For reasons related to the test bench testing phase, this terminal's line is connected to the positive polarity of the electrical system, meeting the need to control the recharge of batteries located near the engine.

If different installation needs require to connect the batteries far from the engine, we recommend changing this connection, cabling the line relating to the **S** terminal of the alternator directly to the positive terminal of the battery.

Instrument and control panel

Supplied on request by IVECO Aifo, this is connected to the EMB with three different lengths of wiring as indicated in the item that follows.

Technical information and data for the manufacture of panels by the Yard must be requested from the IVECO Aifo technical assistance service.

Connecting cable between the indication panel and the EMB

Supplied by IVECO Aifo on request, it is available in 3 different lengths:

- ❑ 3 meters: Drawing 8031150
- ❑ 5 meters: Drawing 8031151
- ❑ 7 meters: Drawing 8031152

Throttle position sensor

After testing the operating condition of the linkage, adjust the stroke of servo components so that:

- ❑ With the throttle at idle, the potentiometer rod is in the resting position and the safety switch inside is electrically open.
The test must be conducted with an ohmmeter between the points D and E of the potentiometer connector:
With readings of:
 $\infty \Omega$ = optimal adjustment
 $1 K\Omega$ = the resting position requires better mechanical adjustment, to bring the value back to $\infty \Omega$
- ❑ With the throttle at the maximum rpm stop, the rod of the potentiometer is in the maximum travel position.

Technical notes for Yard wiring are provided at the end of this section.

Figure 9



Connect to positive terminal of the battery

CONNECTIONS TO THE REGULATOR

Figure 10

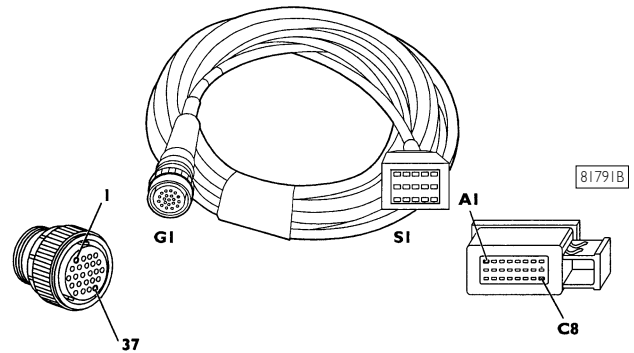

EMB TO PANEL CONNECTING CABLE

Figure 11

TESTING POTENTIOMETER ROD TRAVEL

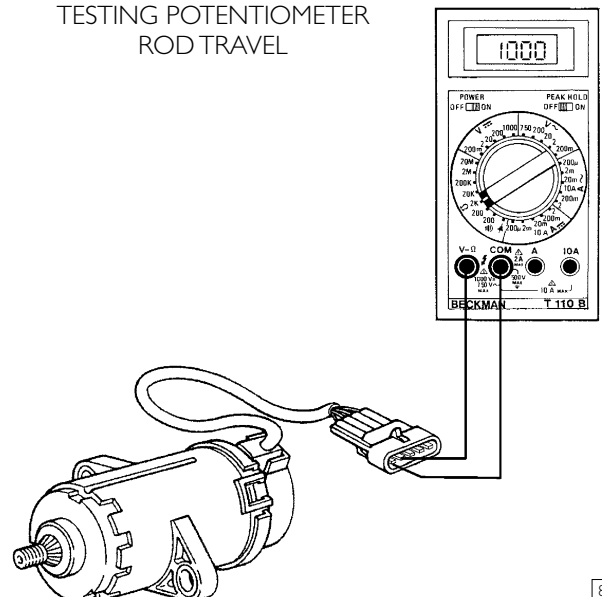

INSTALLATION TESTS

“Common sense” tests, such as exposing heat-sensitive parts to heat (plastic, wiring, electronic units, etc....), and those that for years have characterized the quality of the work performed in yards, are not mentioned herein, although they are of the utmost importance.

Tests to verify the engine's and the electronic control system components' operating condition can be performed quickly and with top reliability using specific diagnostic tools, available to the IVECO Aifo Technical Assistance Centers.

Lubricating oil fill

Lubricating oil transfer operations are simplified by the presence of an electrical control system. Manual controls for transfer and pre-lubrication operations are positioned on the unit above the EMB. For safety reasons, controls are enabled only with the key switch in the “OFF” position

Sequence

1. Place the stable switch in the “ON” position, thus energizing the switching solenoid valve to place the emptying/filling junction in communication with the electrical pump and with the oil sump.
2. Use the intake/exhaust push-button to complete the desired operation.
3. Place the stable switch back to the “OFF” position.

Fuel tank suction

Check assembly suction at the maximum allowed longitudinal and transverse inclinations, with such a residual quantity in the tank as to cause the reserve indicator light to stay on permanently.

Verify the absence of air in the fuel feed pipeline, using a clear pipe placed, in inverted “U” fashion, before the engine inlet.

Throttle position sensor

Verify, in the idling and maximum rpm positions, the correlation between the throttle on the bridge and the sensor rod, noting:

- Whether, with the lever in the idle position, the switch in the sensor is electrically open.
- Whether in the maximum rpm position the sensor rod reaches the mechanical end stop.

Pre-lubrication

The task of pre-lubricating the engine's internal components is managed and controlled by an electronic circuit of the EMB; the operation can also be conducted by acting manually, with the key switch in the “OFF” position, only on the oil intake/exhaust push-button positioned on the related unit. If the push-button is placed for a few seconds in the “EXHAUST” position, the filters and the internal engine ducts will be filled.

Figure 12

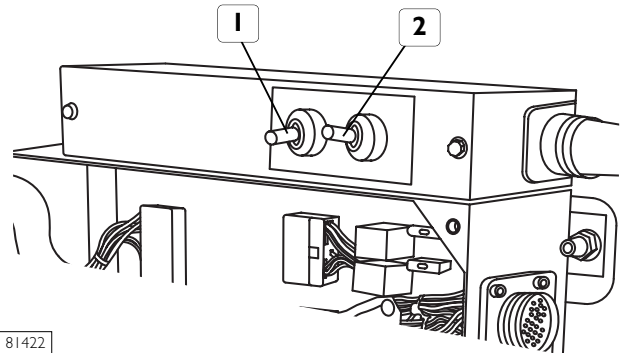

81422

ELECTRICAL LUBRICATING PUMP CONTROLS

1. Oil intake/exhaust control.
2. Switching solenoid valve control.

Figure 13

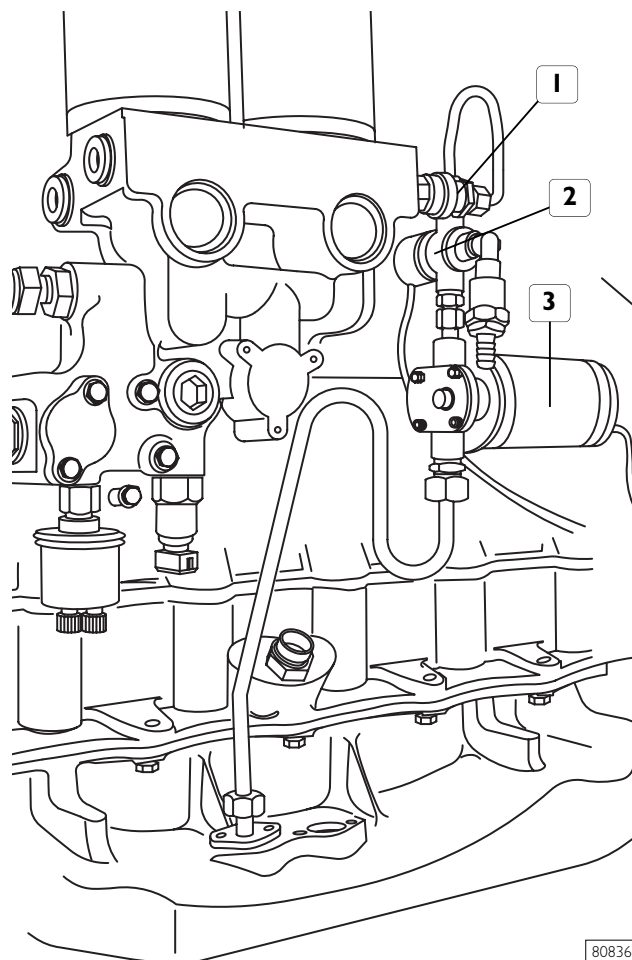

80836

PRE-LUBRICATION SYSTEM

1. One way valve - 2. Switching solenoid valve
3. Electrical pump.

Depending on the manufacturing date, the operating logic for the electronic control may be of two different kinds:

The version manufactured until March 2002 depends on a pressure contact inserted in the lubrication circuit at the outlet of the oil filter assembly, identified in the engine wiring by the J30 connector:

When the key switch is placed and kept in the "START" position, the electrical pre-lubricating pump is powered until the pressure measured reaches about 0.5 bar or for a time interval of up to 10 seconds, during which engine starting is inhibited. Once these phases are completed, the electrical pump is disabled and engine starting is enabled.

Pressure contact specifications

- R at ambient pressure (0 bar) = 0Ω
- R at tripping pressure ($\geq 0,3 \pm 0,15$ bar) = $\infty \Omega$

In the version manufactured starting in April 2002, the pressure switch is replaced by a thermal switch placed to measure the temperature of the liquid in the closed cooling loop identified in the wiring from the same connector J30. If the key switch is placed and held in the "START" position, when the temperature measured by the sensor is $\geq 60^\circ\text{C}$, the engine starts immediately. For lower temperatures, the electrical pre-lubrication pump is powered for about 10 seconds, during which starting is inhibited.

Once the pre-lubrication phase is complete, power to the electrical pump is cut off and starting is enabled.

Thermal switch specifications

- R at ambient temperature = $\infty \Omega$
- R at tripping temperature+ ($\geq 60^\circ\text{C} \pm 3^\circ\text{C}$) = 0Ω

First start

Prepare to re-start the engine as set out in the paragraph entitled "Engine's first start / Restoring normal operating conditions" at the end of this section.

Before starting the engine the first time, it is necessary to completely purge the air from the fuel supply line, acting on the hand pump of the pre-filter or with the aid of a dedicated electrical pump. Purge valves are provided on the pre-filter supplied by IVECO Aifo, downstream of the main filter and on the cylinder head near the injectors' electrical connector.

During the first steps of the engine start, complete the operation from the fitting on the cylinder head.

CAUTION

Carefully prevent the fuel from coming in contact with the auxiliaries drive belt.

Also check that:

- There are no water leaks from the connecting hoses of the cooling loop pipes.
- There are no exhaust gas leaks inside the hull.

Figure 14

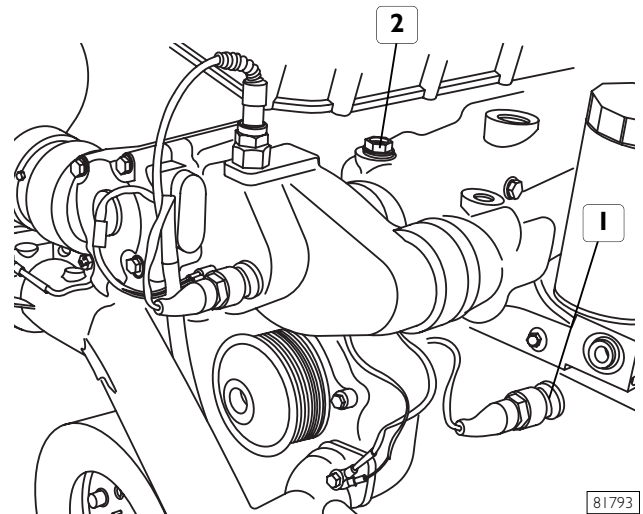

PRE-LUBRICATION SYSTEM SENSORS
1. Pressure switch - 2. Thermal switch location.

Figure 15

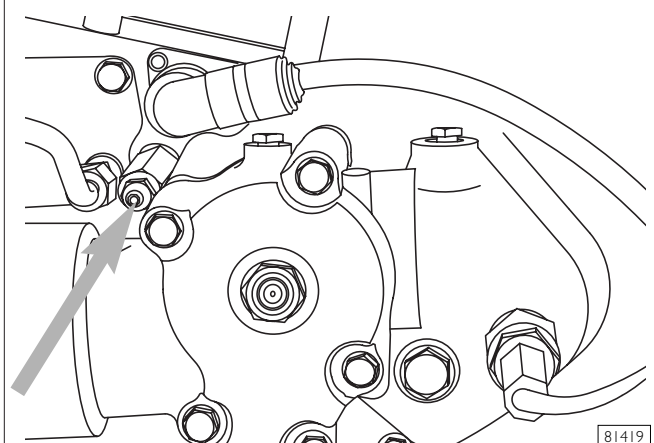

PURGE FITTING ON CYLINDER HEAD

Fuel pressure in fuel supply line

The value of fuel pressure in the transfer loop must be measured from the purge fitting on the cylinder head. We recommend using a manometer with oil-damped needle and end-of-scale at 5 bar. The pressure measured with the engine idling must be about 3.5 bar and tend to rise slightly as engine rpm increases.

Instrument and control panel

Check the operation of all indicator lights simulating the behavior of the sensors connected to them. To reset any errors that may be stored in the engine electronic control unit, proceed as follows:

1. Shut the engine down, rotating the key switch to the "OFF" position.
2. While holding down the diagnosing push-button in the EMB, rotate the key switch to the "ON" position and keep the diagnosing push-button down for at least 5 seconds
3. Release the push-button and rotate the key switch back to the "OFF" position.

At the end of this procedure, the codes of any faults detected during engine installation operations will be deleted from the ECU. To make sure that no fault data remains stored in it, and also that there are no additional faults in the system, proceed as follows:

1. Rotate the key switch to the "ON" position.
2. Press the diagnosing push-button making sure that, after it briefly lights up as a test, the flashing code indicator light remains off.

If the ECU detects the presence of errors or operating anomalies, the indicator light will emit the code of the first stored error with two series of flashes of different frequency; after a few seconds have elapsed from the end of the emission, the codes of any subsequent errors will be emitted if the push-button is pressed again. The repetition of the first of the emitted code will indicate that all information contained in the memory have been emitted.

Such an event will require a review of the installation, in order to remove the cause of the error or of the anomaly. The table containing the explanation of each code is provided in the "DIAGNOSTICS" section.

EMB electrical power

Verify whether the power supply voltage to the H connector, with the engine idling, is no more than 0.4 V smaller than the battery voltage measured during the test.

Shut the engine down, placing the key in the OFF position, and test whether the relay K 1 that powers the electronic engine control unit is de-energized after $2 \div 7$ seconds

ECU temperature

Check whether the temperature of the surface of the electronic engine control unit, after 30 minutes with the engine at maximum power output, is less than +80 °C.

Engine compartment vacuum

Verify that ambient pressure in the engine room, with the engine at full load and maximum power output, complies with the technical data set out herein.

Engine compartment air temperature

Verify that temperature in the engine room, after 30 minutes underway with the engine at maximum power output, does not exceed 50°C, or +15°C over outside temperature.

Fuel temperature

Verify that temperature of the fuel in the transfer line, while underway at maximum power output and with a stable quantity of fuel in reserve does not exceed 80°C. A higher value would lead to a reduction in engine performance due to the safety strategies built in the electronic control unit. If the fuel tends to reach the maximum allowed temperature, install a heat exchanger for the fuel.

Exhaust back-pressure

Verify that the back pressure at the inlet of the exhaust gas duct, with the engine at full load and maximum power output, complies with the technical data set out herein.

Exhaust temperature

Verify that the temperature of the exhaust gas under maximum power conditions is close to the prescribed value.

ON-BOARD PANEL WIRING COMPONENTS

Function	AMP Code®
CPC removable wiring connector EMB side – Component code	182923/1
Female terminal for G I terminal type III +	163082/1
CPC panel connector mounted on EMB – component code G	182918/1
Male terminal for G type III + connector	163084/1
Cable holder for G I connector	182652/1
Removable through-bulkhead connector for panel side wiring – component code S I	20515
Female connector for S I connector	
SICMA 1,5 for 0,35 ÷ 0,75 mm ² section cable	20410
SICMA 1,5 for 1,00 ÷ 1,50 mm ² section cable	20380
SICMA 2,8 for 0,35 ÷ 0,75 mm ² section cable	20415
SICMA 2,8 for 1,00 ÷ 2,50 mm ² section cable	20415
Through-bulkhead panel connector, panel mounted – component code S	20520
Male terminal for S connector	
SICMA 1,5 for 0,35 ÷ 0,75 mm ² section cable	20420
SICMA 1,5 for 1,00 ÷ 1,50 mm ² section cable	20425
SICMA 2,8 for 0,35 ÷ 0,75 mm ² section cable	20430
SICMA 2,8 for 1,00 ÷ 2,50 mm ² section cable	20435
Extractor for G – GI terminals	150807

Figure 16

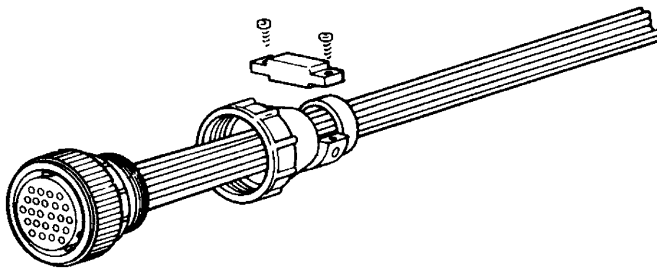

81794A

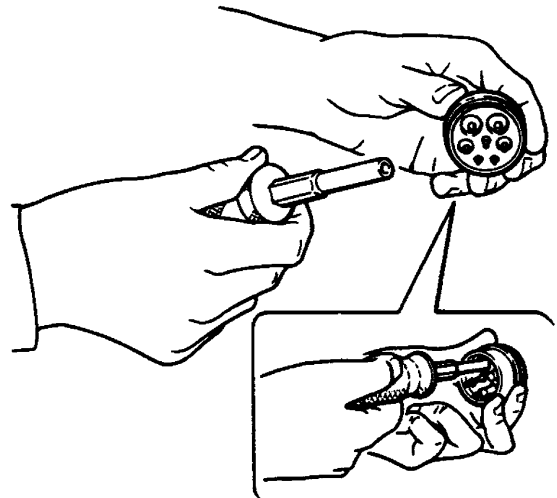

81794B

PREVENTIVE MAINTENANCE IN CASE OF PROLONGED ENGINE INACTIVITY

To prevent oxidation to the inner parts of the engine and some components of the injection system, if periods of inactivity exceeding two months are expected, the engine must be prepared every six months by proceeding as follows:

1. Drain the lubricating oil from the sump, after heating the engine.
2. Fill the engine with protective oil type 30/M (or MIL 2160B type 2) up to the "minimum" level indicated on the dipstick.
Start the engine and let it run for about 5 minutes.
3. Drain the fuel from the injection line, from the filter and from the ducts in the cylinder heads. To do so, loosen the drain cap in the front part of the cylinder head and the fuel inlet junction with the cylinder head, taking care to prevent the fuel from coming in contact with the auxiliaries belt. See "First start" paragraph at page 13 in this section.
4. Connect the fuel line with a tank containing CFB protective liquid (ISO 4113) and let the liquid enter the by pressurizing the line and turning the engine over for about 2 minutes, after excluding the operation of the injection system. The required operation can be completed by directly polarizing the terminal 50 of the electric starter motor with 24V positive voltage, by means of a conductor prepared for the occasion.
5. Nebulize about 80 g (10 g per liter of displacement) of protective oil type 30/M into the intake mouth of the turbocharger, while turning the engine over as described in the previous paragraph.
6. Close all the engine's intake, exhaust, aeration and vent ports with appropriate caps or seal with adhesive tape.
7. Drain from the oil sump the residual protective oil type 30/M, which may be reused for 2 more engine lay-ups.
8. Apply tags bearing the inscription "ENGINE WITHOUT LUBE OIL" on the engine and on the panel.
9. Drain the cooling liquid if it is not mixed with anticorrosive substances.

If exterior parts of the engines are to be protected as well, spray OVER 19 AR protective liquid on unpainted metal parts, such as flywheel, pulleys and others, taking care not to spray it on belts, connecting cables and electrical equipment.

ENGINE'S FIRST START / RESTORING NORMAL OPERATING CONDITIONS

1. Drain the residual protective oil type 30/M from the sump.
2. Pour lubricating oil into the engine, as provided by the specifications and in the quantities set out in the Table of Refills.
3. Drain the CFB protective liquid from the fuel line, completing the operations set out in item 3 of "PREVENTIVE MAINTENANCE IN CASE OF PROLONGED ENGINE INACTIVITY".
4. Remove the caps and/or the seals from the engine's intake, exhaust, aeration and vent ports, restoring normal operating conditions. Connect the turbocharger intake to the air filter.
5. Attach the fuel lines to the vessel's fuel tank, completing the operations set out in item 4 of "PREVENTIVE MAINTENANCE IN CASE OF PROLONGED ENGINE INACTIVITY". During the filling operations, attach the fuel tank return pipe to a collecting container to prevent residues of CFB protective liquid from flowing into the vessel's fuel tank.
6. Verify the quantity of cooling liquid and refill as provided by the specifications.
7. Start the engine and keep it running until idling speed has completely stabilized.
8. Shut the engine down and delete the "errors" which may have been stored in the injection system ECU during the operation stabilization phases. For reset operation, see "Blink code" paragraph at page 3 in the next section.
9. Remove the tags with the inscription "ENGINE WITHOUT LUBE OIL" from the engine and from the panel.

SECTION 3

Diagnostics

	Pagina
ECU BEHAVIOR	3
<input type="checkbox"/> Fault indicator light	3
<input type="checkbox"/> Blink code	3
<input type="checkbox"/> Fault memory reset	3
<input type="checkbox"/> Recovery	3
BLINK CODE TABLE	4

ECU BEHAVIOR

Fault Indicator Light

The ECU continuously monitors its own operating conditions as well as those of the components connected to it and of the engine itself, with complex self-diagnostics routines. If faults are detected, the fault indicator light on the indications and control panel is lit in ways that provide an initial indication of the severity of the problem.

Light off: no fault detected or minor fault that does not compromise operating safety.

Light on: significant fault, allowing to proceed to a diagnostics center.

Blinking light: severe fault, requiring immediate servicing. If circumstances allow shutting the engine down.

Blink code

The emission of the fault codes detected by the self-diagnostics routines and stored in the ECU starts after the push-button located on the relay and fuse board is pressed and released. The LED to the side of the push-button and the EDC indicator light on the indications and control panel will simultaneously signal the codes by blinking two series of emissions at different frequency, reproducing the digits indicating the fault with decimal numbering.

Slow blinking indicates the area of the fault (engine, injectors, ...), **fast blinking** indicates a specific fault.

Every time the push-button is pressed and released, only one of the stored codes is emitted; therefore, the procedure needs to be repeated until the system emits the same error data as the first one: this will mean that the entire fault memory has been analyzed.

If no anomalies are stored, the light comes on when the push-button is pressed and comes off about 1 second after it is released, without blinking.

Note: The blink code diagnostic procedure provides indications about faults that are currently present but also about other faults, which arose in the past and are no longer present at the time of the diagnostic procedure. Therefore, it is absolutely necessary, at the end of each servicing operation, to reset the error memory to prevent the system from signaling faults, in the future, whose cause has already been removed.

Fault memory reset

In current applications, the reset operation is carried out keeping the blink code push-button pressed down with the key switch in the OFF position and keeping it pressed for 5 more seconds are setting the switch to ON. Confirmation of the reset will be obtained by turning the key switch from OFF to ON and requesting blink codes again: at that point, no codes should be produced.

Recovery

Associated to the detection of significant or severe faults, the ECU adopts strategies that, to allow safe use of the engine, limit some injection parameters within pre-set thresholds according to the severity of the situation.

As a result of these strategies, the engine's maximum power output is reduced. In case of intermittent faults, i.e. faults that are detected by the ECU and subsequently are no longer present, performance reduction will be active until the engine is shut down.

Normal operation will be restored only at the subsequent start-up, while the fault data will be "saved" in the fault memory.

BLINK CODE TABLE

Blinking Code	EDC Indicator light	Indicated Fault
Control area		
1.1	(on)	not significant in marine applications
1.2	(on)	not significant in marine applications
1.3	(off)	not significant in marine applications
1.4	on	throttle position sensor
1.5	(off)	not significant in marine applications
1.6	(on)	not significant in marine applications
1.7	(off)	not significant in marine applications
Engine area		
2.1	off	coolant temperature sensor
2.2	off	intake air temperature sensor
2.3	off	fuel temperature sensor
2.4	on	supercharge air pressure sensor
2.5	off	ambient pressure sensor (inside the unit)
2.6	(on)	not significant in marine applications
3.5	off	battery voltage
Injectors		
5.1	on	cylinder 1 injector fault
5.2	on	cylinder 2 injector fault
5.3	on	cylinder 3 injector fault
5.4	on	cylinder 4 injector fault
5.5	on	cylinder 5 injector fault
5.6	on	cylinder 6 injector fault
Engine rpm sensor		
6.1	on	flywheel sensor
6.2	on	timing system sensor
6.4	blinking	runaway engine
Electronic unit		
9.1	blinking	defective unit
9.2	on	incorrect EEPROM data
9.3	(blinking)	not significant in marine applications
9.4	on	main relay
9.5	on	erroneous engine shut-down procedure
9.6	on	unit data storage operation not completed

NOTES

A large rectangular area filled with a fine grid of small squares, intended for writing notes. The grid covers most of the page below the 'NOTES' header.

NOTES

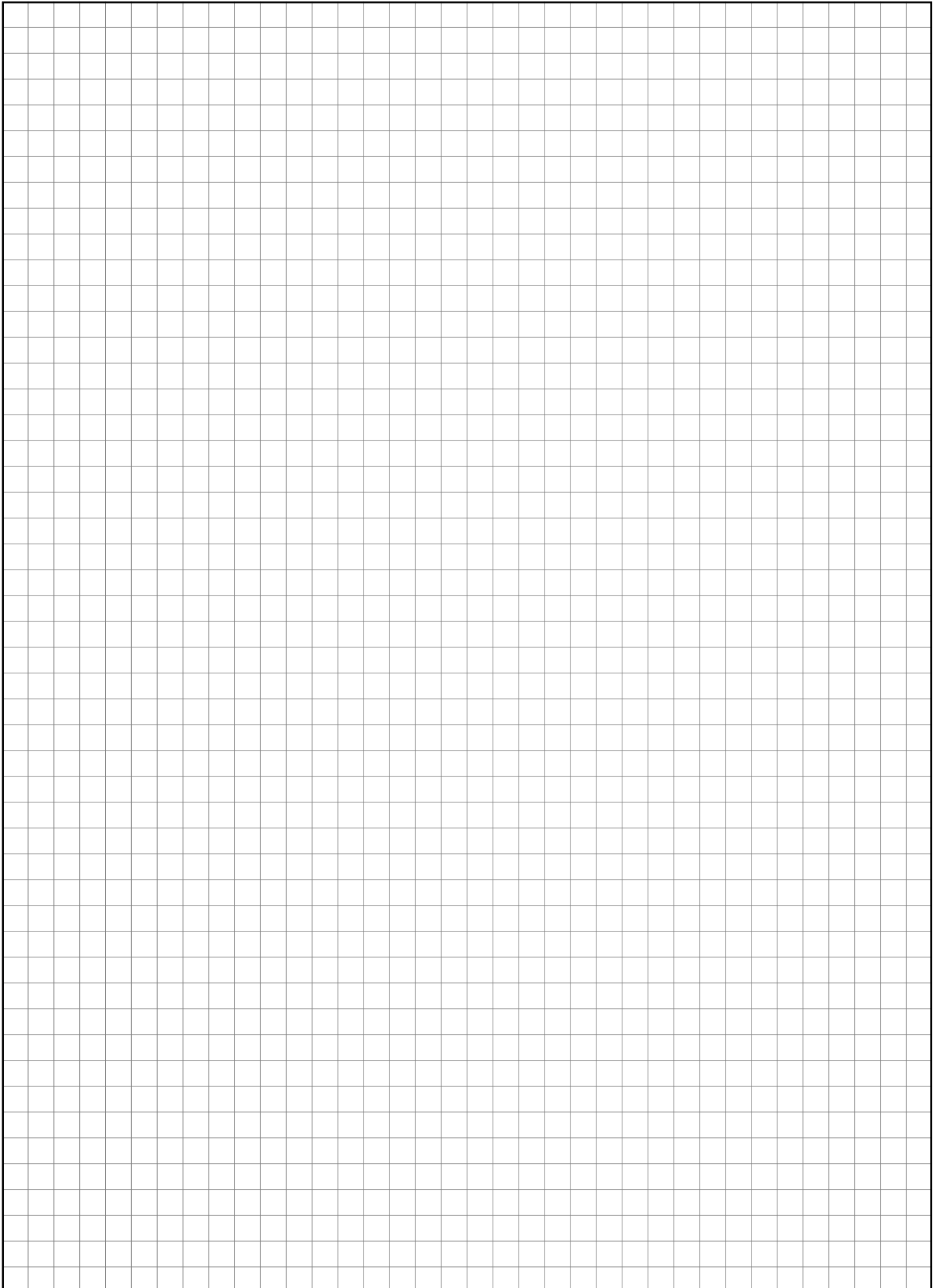

IVECO *aifo*

Iveco Aifo S.p.A.

Viale Dell'Industria, 15/17

20010 Pregnana Milanese - MI - (Italy)

Tel. +39 02 93.51.01 - Fax +39 02 93.59.00.29

www.iveco.com