

**SPECIFICATIONS**

Engine		C78 ENT M30	C78 ENT M50	C78 ENT M55
Cycle		4-Stroke Diesel		
Charge		Supercharged and intercooled		
Injection		Direct		
Number of cylinders		6 in line		
Bore	mm	115		
Stroke	mm	125		
Total displacement	cm <sup>3</sup>	7790		
Compression ratio		16,5 ± 0,8 to 1	16 ± 0,8 to 1	16 ± 0,8 to 1
Direction of rotation, flywheel side		counterclockwise		
Minimum idling rpm	rpm	600 ± 25		
Maximum engine rpm, no load	rpm	2160 ± 25	2800 ± 25	2800 ± 25
<b>Allowed engine inclination angles</b>				
Maximum longitudinal in continuous operation (static + dynamic)	degrees/360	+ 20°		
Maximum transverse in continuous operation (static + dynamic)	degrees/360	± 22° 30'		
Longitudinal for oil level check with standard dipstick	degrees/360	0 to +10°		
<b>Supercharge</b>				
Turbocompressor with water-cooled body		KKK K27	KKK K31	HX 55WM
Pressure regulation		-	with separated waste-gate	with integrated waste-gate
Waste-gate maximum opening pressure	bar	-	2,0 ± 0,1	2,6 ± 0,1
<b>Lubrication</b>				
Oil	type	SAE 15 W 40/E 3		
Oil compliant with specifications		ACEA E3/API CF4/MIL L2104E/F		
Total oil capacity on first filling	liters (kg)	31 (28)		
Total oil capacity with sump at minimum level	liters (kg)	18 (16,3)		
Total oil capacity with sump at top level	liters (kg)	25 (22,7)		
Oil pressure, warm engine, minimum idling rpm	bar	≥ 1,5		
Oil pressure, warm engine, maximum rpm	bar	≥ 5		
Maximum allowed temperature	°C	105		
Oil dipstick valid for static inclination	degrees/360	0 to +10°		
<b>Fuel supply</b>				
Fuel oil compliant with standard		EN 590		
Low pressure transfer pump		gear pump		
Flow rate at maximum rpm	kg/h	68	88	88
Fuel return flow rate to tank	kg/h	≤ 12		
Filtering: pre filter	µm	36,5		
Filtering: filter	µm	5		

Engine		C78 ENT M30	C78 ENT M50	C78 ENT M55
<b>Injection system</b>				
Type		pump - injectors (EUI)		
System		Bosch EDC MS 6.2		
Maximum injection pressure	bar	1600		
<b>Low temperature starting</b>				
Allowed, without external aids, down to	°C	-15		
With electrical heating of intake air (optional), down to	°C	-25		
With additional external heater, down to	°C	-30		
<b>Cooling</b>				
Closed coolant loop with sea water heat exchanger		50% mixture of water/Paraflu II or equiv. Compliant with SAE J 1034 specification		
Total coolant quantity	liters	~ 40		
Engine-only capacity	liters	~ 15,5		
Expansion tank		standard		
Forced circulation		centrifugal pump		
Flow rate at maximum rpm	l/h	18900	25200	25200
Temperature regulation		with thermostatic valve		
Initial opening	°C	68 ± 2		
Sea water line	°C	78 ± 2		
Sea water line		forced circulation		
Sea water pump		volumetric self-priming with neoprene impeller	centrifugal self-priming	
Max. pump capacity	l/h	15500	17500	20000
<b>Exhaust gas expulsion</b>				
Optional		stack		
Optional		riser		
<b>Electrical system</b>				
Nominal voltage	Vcc	24		
Self-regulated alternator:				
Voltage	Vcc	29		
Maximum current intensity	A	90		
Electrical starter motor:				
Nominal voltage	V	24		
Absorbed electrical power	W	4500		
Recommended batteries capacity	Ah	≥ 120		
Current discharge at - 18 °C (SAE J 537)	A	≥ 900		

Engine		C78 ENT M30	C78 ENT M50	C78 ENT M55
<b>Drive train coupling</b>				
Flywheel diameter	mm (inches)		355 (14)	
Flywheel case	type		SAE 1	
<b>Weights</b>				
Without liquids and without gearbox	kg	900	910	910

**Dimensions**

Figure 1

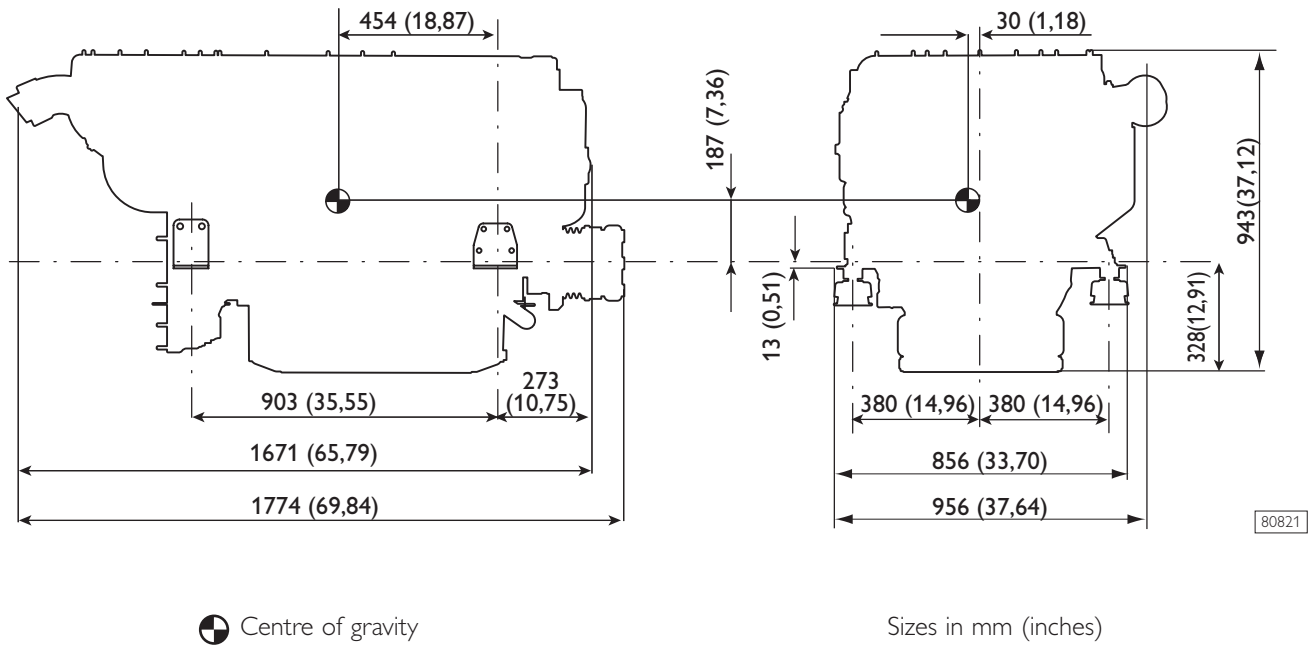

**SPECIFICATIONS**

Engine		C78 ENS M20
Cycle		4-Stroke Diesel
Charge		Supercharged
Injection		Direct
Number of cylinders		6 in line
Bore	mm	115
Stroke	mm	125
Total displacement	cm <sup>3</sup>	7790
Compression ratio		16,5 ± 0,8 to 1
Direction of rotation, flywheel side		counterclockwise
Minimum idling rpm	rpm	600 ± 25
Maximum engine rpm, no load	rpm	2190 ± 25
<b>Allowed engine inclination angles</b>		
Maximum longitudinal in continuous operation (static + dynamic)	degrees/360	+ 20°
Maximum transverse in continuous operation (static + dynamic)	degrees/360	± 22° 30'
Longitudinal for oil level check with standard dipstick	degrees/360	0 to +10°
<b>Supercharge</b>		
Turbocompressor with water-cooled body		KKK K27
Pressure regulation		-
Waste-gate maximum opening pressure	bar	-
<b>Lubrication</b>		
Oil	type	SAE 15 W 40/E 3
Oil compliant with specifications		ACEA E3/API CF4/MIL L2104E/F
Total oil capacity on first filling	liters (kg)	31 (28)
Total oil capacity with sump at minimum level	liters (kg)	18 (16,3)
Total oil capacity with sump at top level	liters (kg)	25 (22,7)
Oil pressure, warm engine, minimum idling rpm	bar	≥ 1,5
Oil pressure, warm engine, maximum rpm	bar	≥ 5
Maximum allowed temperature	°C	105
Oil dipstick valid for static inclination	degrees/360	0 to +10°
<b>Fuel supply</b>		
Fuel oil compliant with standard		EN 590
Low pressure transfer pump		gear pump
Flow rate at maximum rpm	kg/h	68
Fuel return flow rate to tank	kg/h	≤ 12
Filtering: pre filter	µm	36,5
Filtering: filter	µm	5

Engine		C78 ENS M20
<b>Injection system</b>		
Type		pump - injectors (EUI)
System		Bosch EDC MS 6.2
Maximum injection pressure	bar	1600
<b>Low temperature starting</b>		
Allowed, without external aids, down to	°C	-15
With electrical heating of intake air (optional), down to	°C	-25
With additional external heater, down to	°C	-30
<b>Cooling</b>		
Closed coolant loop with sea water heat exchanger		50% mixture of water/Paraflu II or equiv. Compliant with SAE J 1034 specification
Total coolant quantity	liters	~ 40
Engine-only capacity	liters	~ 15,5
Expansion tank		standard
Forced circulation		centrifugal pump
Flow rate at maximum rpm	l/h	18900
Temperature regulation		with thermostatic valve
Initial opening	°C	68 ± 2
Sea water line	°C	78 ± 2
Sea water line		forced circulation
Sea water pump		volumetric self-priming with neoprene impeller      centrifugal self-priming
Max. pump capacity	l/h	15500
<b>Exhaust gas expulsion</b>		
Optional		stack
Optional		riser
<b>Electrical system</b>		
Nominal voltage	Vcc	24
Self-regulated alternator:		
Voltage	Vcc	29
Maximum current intensity	A	90
Electrical starter motor:		
Nominal voltage	V	24
Absorbed electrical power	W	4500
Recommended batteries capacity	Ah	≥ 120
Current discharge at - 18 °C (SAE J 537)	A	≥ 900

Engine

C78 ENS  
M20

**Drive train coupling**

Flywheel diameter	mm (inches)	355 (14)
Flywheel case	type	SAE 1

**Weights**

Without liquids and without gearbox	kg	900
-------------------------------------	----	-----

**Dimensions**

Figure 1

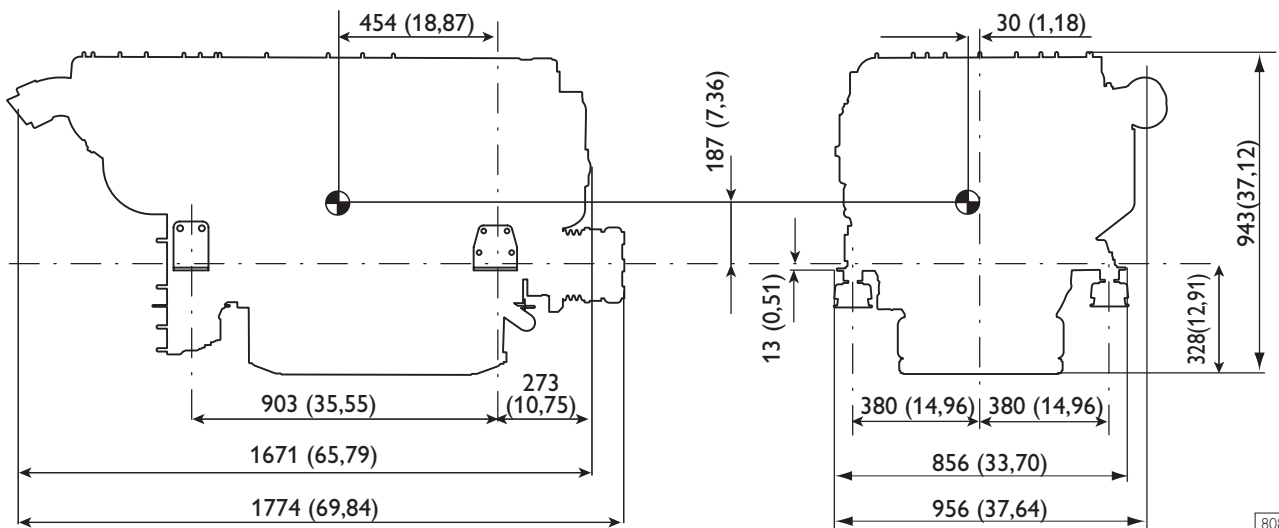









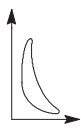
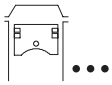

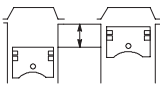
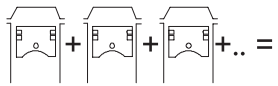
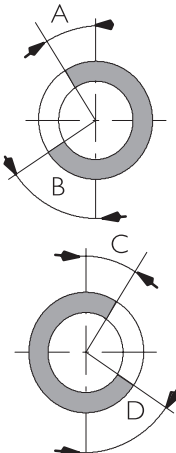
☉ Centre of gravity



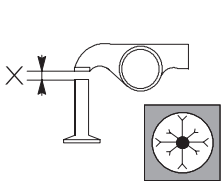



Sizes in mm (inches)

80821

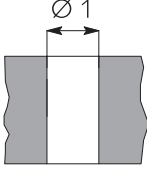
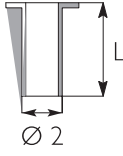

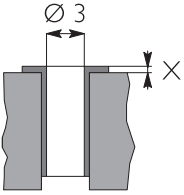
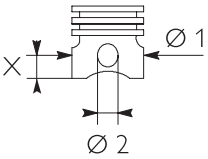

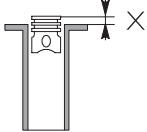
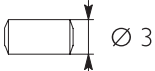

## GENERAL CHARACTERISTICS



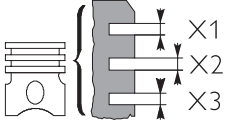
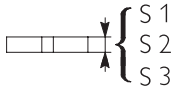

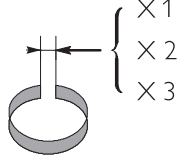
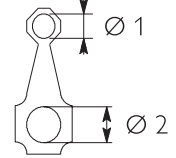
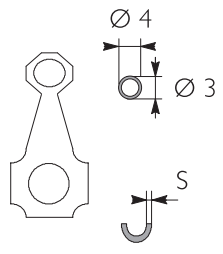
Engine		C78 ENS M20 C78 ENT M30	C78 ENT M50	C78 ENT M55
<b>mm</b>				
	Cycle	Diesel 4 strokes		
	Air feeding	Turbocharged with aftercooler		
	Injection	Direct		
	N. of cylinders	6 in-line		
	Diameter	mm	115	115
	Stroke	mm	125	
	Total displacement	cm <sup>3</sup>	7790	
<b>e</b>	Compression ratio		16,5 ± 0,8 : 1	16 ± 0,8 : 1
	<b>Valve timing</b>			
	 opens before TDC      A			17°
	 closes after BDC      B			31°
	 opens before BDC      D			48°
	 closes after TDC      C			9°
	For timing check			
	 	X	$\left\{ \begin{array}{l} \text{mm} \\ \text{mm} \end{array} \right.$	- -
	Running			
	 	X	$\left\{ \begin{array}{l} \text{mm} \\ \text{mm} \end{array} \right.$	0.40 to 0.50 0.40 to 0.50



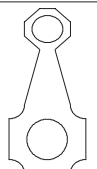

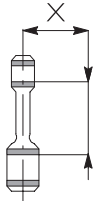
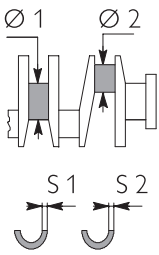
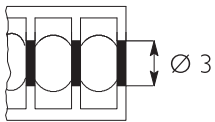

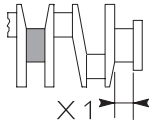
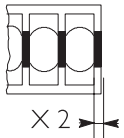
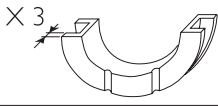

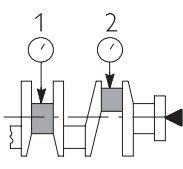

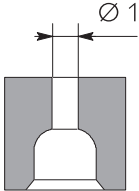
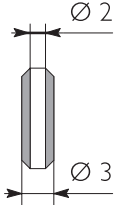

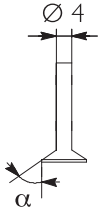

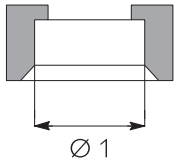

## ASSEMBLY CLEARANCE DATA

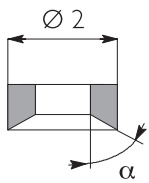

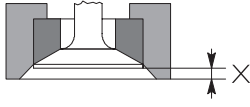
Engine	C78 ENS M20 C78 ENT M30	C78 ENT M50	C78 ENT M55
Cylinder block and crank mechanism components		mm	
	Cylinder sleeve bore  Ø 1	upper lower	130.200 to 130.225 128.510 to 128.535
	Cylinder liners: outer diameter:  Ø 2 length	upper lower L	130.161 to 130.186 128.475 to 128.500 -
	Cylinder sleeve - crankcase bore:	upper lower	0.014 to 0.064 0.010 to 0.060
	Outside diameter	Ø 2	-
	Cylinder sleeve  inside diameter  Protrusion  * Available dia. class	A* Ø 3 B* X	115.000 to 115.012 115.010 to 115.022 0.035 to 0.065
	Pistons : measuring dimension outside diameter outside diameter pin bore  * Class A pistons supplied as spares. ** Class B pistons are fitted in production only and are not supplied as spares.	X Ø 1 A* Ø 1 B** Ø 2	18 114.888 to 114.900 114.898 to 114.910 46.010 to 46.016
	Piston - cylinder sleeve		0.100 to 0.124
	Piston diameter	Ø 1	-
	Pistons protrusion	X	0.32 to 0.69
	Gudgeon pin	Ø 3	45.994 to 46.000
	Gudgeon pin - pin housing		0.010 to 0.024





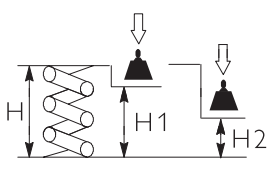
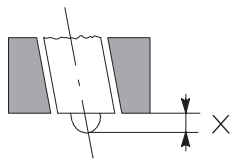
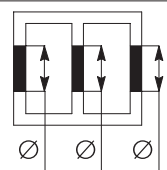
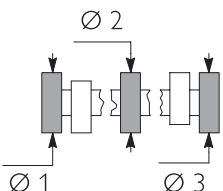
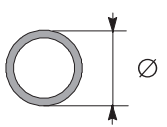
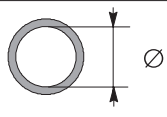

Engine		C78 ENS M20 C78 ENT M30	C78 ENT M50	C78 ENT M55
mm				
	Piston ring grooves * Measured on Ø of 112 mm	X1* X2 X3 2,71 to 2,74 2,55 to 2,57	3,10 to 3,12 2,56 to 2,58 4.02 to 4.04	
	Piston rings: trapezoidal seal lune seal milled scraper ring with slits and internal spring * Measured on Ø of 112 mm	S1* S2 S3 2,575 to 2,595 2,470 to 2,490	3,000 2,470 to 2,500 3.975 to 3.990	
	Piston rings - grooves	1 2 3 0,115 to 0,165 0,070 to 0,96	0,100 to 0,120 0,060 to 0,100 0.030 to 0.065	
	Piston rings		-	
	Piston ring end gap in cylinder liners:	X1 X2 X3 X1 X2 X3	0.35 to 0.50 0.70 to 0.96 0.30 to 0.60	
	Small end bush housing Big end bearing housing Selection classes Ø 2	Ø 1 Ø 2 1 2 3	Rated value 49.975 to 50.000 77.000 to 77.030 77.000 to 77.010 77.011 to 77.020 77.021 to 77.030	
	Small end bush diameter outside inside Big end bearing shell Red Green Yellow * * Fitted in production only and not supplied as spares	Ø 4 Ø 3 S Ø 4 Ø 3 S	50.055 to 50.080 46.015 to 46.030 2.000 to 2.010 2.011 to 2.020 2.021 to 2.030	
	Small end bush - housing		0.055 to 0.105	
	Piston pin - bush		0.015 to 0.036	
	Big end bearing shells		0.127 - 0.254 - 0.508	
	Connecting rod weight Class	A B C	g. 2890 to 2920 g. 2921 to 2950 g. 2951 to 2980	

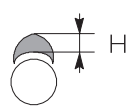
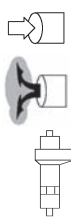
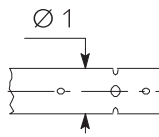
Engine	C78 ENS M20 C78 ENT M30	C78 ENT M50	C78 ENT M55
		mm	
	Measuring dimension X	125	
	Max. connecting rod axis misalignment tolerance =	0.08	
	Main journals $\varnothing 1$ Selection class $\left\{ \begin{array}{l} 1 \\ 2 \\ 3 \end{array} \right.$ Crankpins $\varnothing 2$ Selection class $\left\{ \begin{array}{l} 1 \\ 2 \\ 3 \end{array} \right.$ Main bearing shells S1 Red Green Yellow * Big end bearing shells S2 Red Green Yellow * * Fitted in production only and not supplied as spares	Rated value 82.910 to 82.940 82.910 to 82.919 82.920 to 82.929 82.930 to 82.940 Rated value 72.915 to 72.945 72.915 to 72.924 72.925 to 72.934 72.935 to 72.945	
	Main bearing housings $\varnothing 3$ Selection class $\left\{ \begin{array}{l} 1 \\ 2 \\ 3 \end{array} \right.$	Rated value 89.000 to 89.030 89.000 to 89.009 89.010 to 89.019 89.020 to 89.030	
	Bearing shells - main journals Bearing shells - big ends	0.040 to 0.098 0.035 to 0.093	
	Main bearing shells Big end bearing shells	0.127 - 0.254 - 0.508 0.127 - 0.254 - 0.508	
	Main journal, thrust bearing X1	39.96 to 40.04	
	Main bearing housing, thrust bearing X2	32.94 to 32.99	
	Thrust washer halves X3	3.38 to 3.43	
	Driving shaft shoulder	0.11 to 0.34	
	Alignment $\left\{ \begin{array}{l} \parallel \\ \text{O} \end{array} \right.$ Ovality $\left\{ \begin{array}{l} 1 - 2 \\ \text{V/O} \end{array} \right.$ Taper $\left\{ \begin{array}{l} 1 - 2 \\ \text{V/O} \end{array} \right.$	$\leq 0.05$ - 0.010 0.010	

Engine	C78 ENS M20 C78 ENT M30	C78 ENT M50	C78 ENT M55
<b>Cylinder heads - valve train</b>	<b>mm</b>		
 <p>Valve guide housings in cylinder head</p>	Ø 1	12.980 to 12.997	
 <p>Valve guide</p>	Ø 2 Ø 3	8.023 to 8.038 13.012 to 13.025	
 <p>Valve guides - housings in the cylinder heads</p>		0.015 to 0.045	
 <p>Valve guide</p>		-	
 <p>Valves:</p>	 Ø 4 α  Ø 4 α	7.970 to 7.985 60° 30' ± 7' 30'' 7.970 to 7.985 45° 30' ± 7' 30''	
 <p>Valve stem and its guide</p>		0.038 to 0.068	
 <p>Housing in head for valve seat:</p>	 Ø 1  Ø 1	41.985 to 42.020 40.985 to 41.020	
 <p>Outside diameter of valve seat; angle of valve seat in cylinder head:</p>	 Ø 2 α  Ø 2 α	42.060 to 42.075 60° - 30' 41.060 to 41.075 45° - 30'	
 <p>Recessing of valve</p>	 X  X	0.5 to 0.8 1.6 to 1.9	
 <p>Between valve seat and head</p>	 	0.040 to 0.090	

Engine	C78 ENS M20 C78 ENT M30	C78 ENT M50	C78 ENT M55
		mm	
 <p>Valve outside spring height:</p> <p>free height H</p> <p>under a load of: N 454 ± 22 H1 N 840 ± 42 H2</p>		62.6	48.5 36.5
 <p>Injector protrusion X</p>	X	0.7	
 <p>Camshaft bush housing fitted in the cylinder head:</p> <p>1 → 7 Ø</p>	Ø	80.000 to 80.030	
 <p>Camshaft journal diameter:</p> <p>1 → 7 Ø</p>	Ø	75.924 to 75.940	
 <p>Camshaft bushing outer diameter Ø</p>	Ø	80.090 to 80.115	
 <p>Camshaft bushing inner diameter Ø</p>	Ø	75.990 to 76.045	
 <p>Bushings and housings in engine block</p>		0.060 to 0.115	
 <p>Bushings and journals</p>		0.050 to 0.121	
 <p>Cam lift:</p>		8.07 7.63 8.80 to 8.82	
 <p>Rocker shaft Ø 1</p>	Ø 1	37.984 to 38.000	

Engine	C78 ENS M20 C78 ENT M30	C78 ENT M50	C78 ENT M55
	mm		
<p data-bbox="453 384 624 436">Bushing housing in rocker arms:</p> 		41.000 to 41.016	41.000 to 41.016
<p data-bbox="453 711 703 764">Bushing outer diameter for rocker arms:</p> 		41.097 to 41.135	41.097 to 41.135
<p data-bbox="453 1039 703 1092">Bushing inner diameter for rocker arms:</p> 		38.025 to 38.041	38.025 to 38.041
<p data-bbox="453 1367 647 1419">Between bushings and housings:</p> 		0.081 to 0.135	0.081 to 0.135
<p data-bbox="453 1694 684 1747">Between rocker arms and shaft:</p> 		0.025 to 0.057	0.025 to 0.057
		0.015 to 0.087	

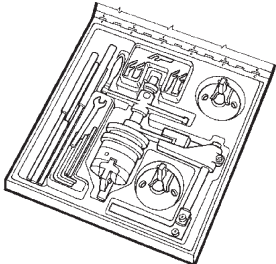
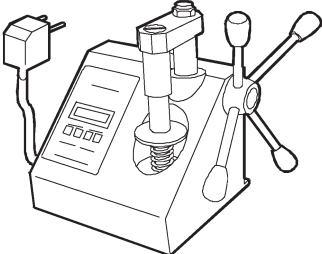
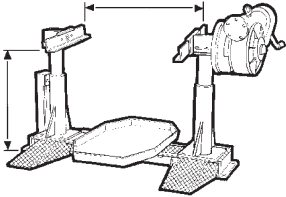
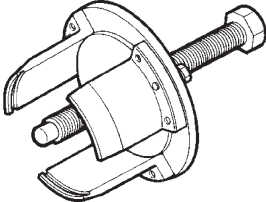
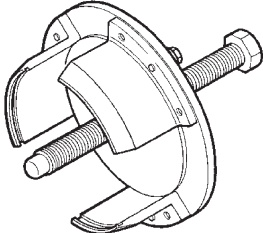
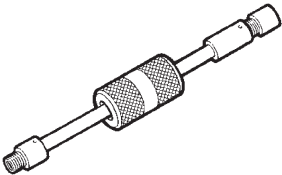

**TOOLS**

Tool No.	Description
<b>99305019</b>	Full-optional tool-kit to rectify valve seat
	
<b>99305047</b>	Equipment for spring load check
	
<b>99322230</b>	Rotary telescopic stand
	
<b>99340051</b>	Extractor for crankshaft front gasket
	
<b>99340052</b>	Extractor for crankshaft rear gasket
	
<b>99340205</b>	Percussion extractor
	

## TOOLS

Tool No.	Description
99342148	Injector extractor
99342149	Extractor for injector-holder
99346245	Tool to install the crankshaft front gasket
99346246	Tool to install the crankshaft rear gasket
99348004	Universal extractor for 5 to 70 mm internal components
99350072	Box wrench for transmission gear support fixing screws

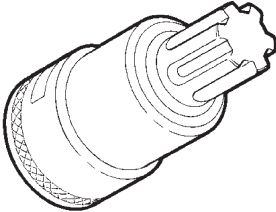
**TOOLS**

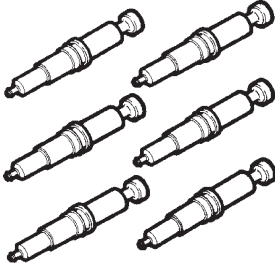
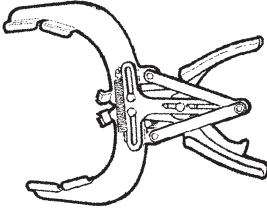
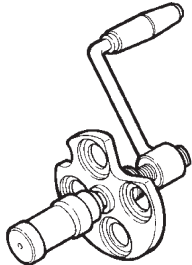
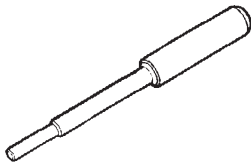

Tool No.	Description
<b>99350074</b>	Box wrench for block junction bolts to the underblock
	
<b>99360144</b>	Skid retaining tools (12+6) for rocker arm adjusting screws during rocker arm shaft removal/refitting
	
<b>99360177</b>	Injector housing plug
	
<b>99360184</b>	Pincers for removing and refitting circlips and pistons (105 - 160 mm)
	
<b>99360264</b>	Tool to take down-fit engine valves
	
<b>99360288</b>	Tool to remove valve guide
	

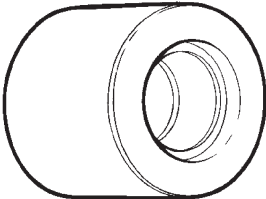
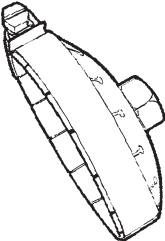
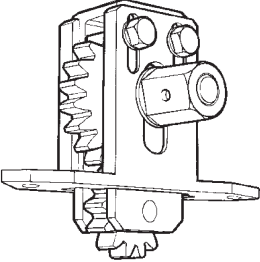
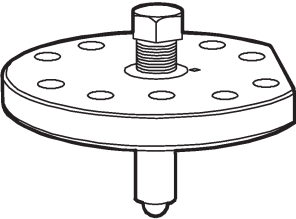
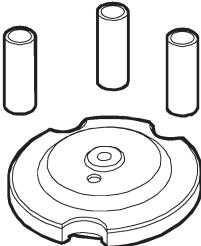

## TOOLS

Tool No.	Description
99360292	Tool to install gasket on valve guide
	
99360294	Tool to drive valve guide
	
99360314	Tool to remove cartridge filters
	
99360321	Tool to rotate engine flywheel
	
99360334	Tool for checking cylinder barrel projection
	
99360335	Cylinder barrel compression cap (to be used with 99360334)
	

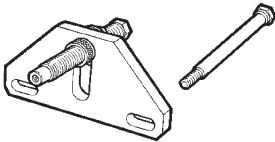
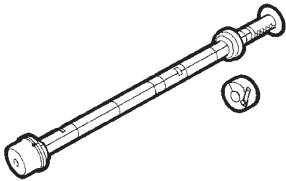
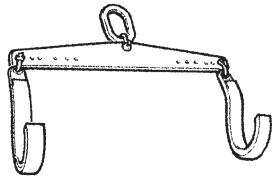
**TOOLS**

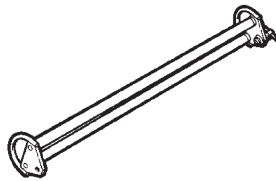
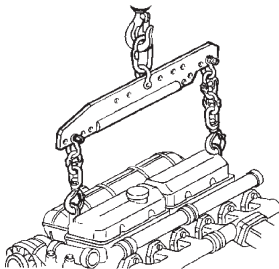
Tool No.	Description
<b>99360351</b>	Tool to stop engine flywheel
	
<b>99360487</b>	Tool to take down and fit back camshaft bushes
	
<b>99360500</b>	Tool to lift crankshaft
	
<b>99360551</b>	Bracket to take down and fit engine flywheel
	
<b>99360558</b>	Tool to lift and transport rocker shaft
	
<b>99360585</b>	Balance for lifting and handling engine
	

## TOOLS

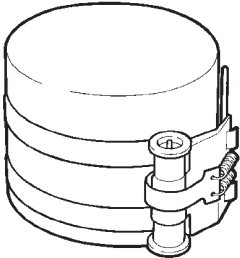
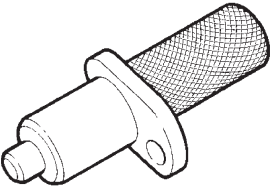
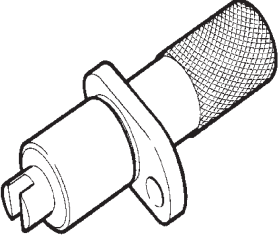
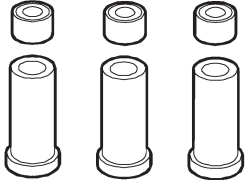
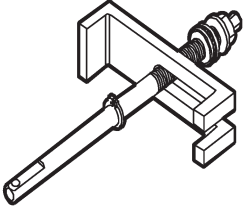
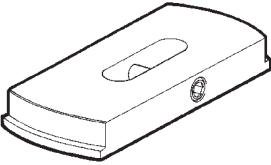
Tool No.	Description
99360605	Belt to insert piston in cylinder liner (60 - 125 mm)
	
99360612	Engine flywheel timing pin
	
99360613	Tool for timing of phonic wheel on timing gear
	
99360703	Tool to stop cylinder liners
	
99360706	Tool to extract cylinder liners
	
99360724	Tool to extract the cylinder liners (to be used with 99360723)
	

**TOOLS**

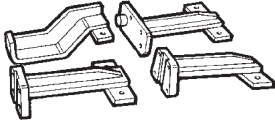
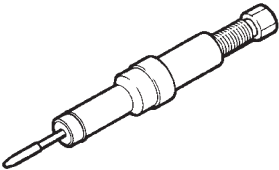
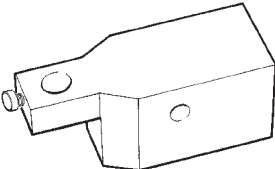
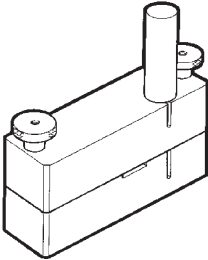
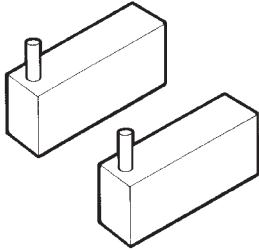
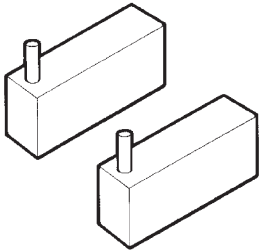
Tool No.	Description	
<b>99361035</b>		Brackets fixing the engine to rotary stand 99322230
<b>99365054</b>		Tool for injector holder heading
<b>99370415</b>		Tool to detect cylinder liner projections (use with 99395603)
<b>99378100</b>		Tool for printing engine identification plates (to be used with special punches)
<b>99378101</b>		Punches ( <b>A</b> ) for printing engine identification plates (to be used with 99378100)
<b>99378102</b>		Punches ( <b>B</b> ) for printing engine identification plates (to be used with 99378100)

## TOOLS

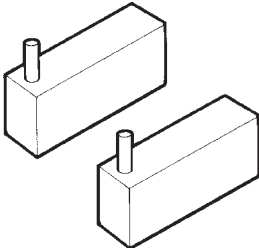
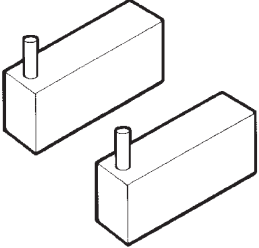
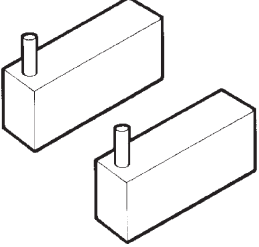
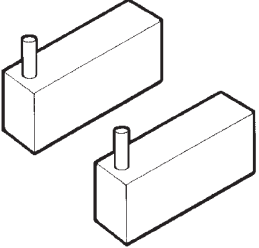
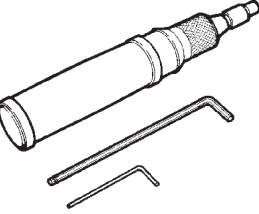
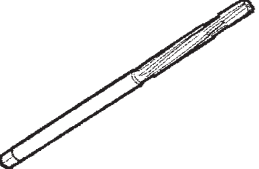
Tool No.	Description
<b>99378103</b>	Punches ( <b>C</b> ) for printing engine identification plates (to be used with 99378100)
	
<b>99378104</b>	Punches ( <b>D</b> ) for printing engine identification plates (to be used with 99378100)
	
<b>99378105</b>	Punches ( <b>E</b> ) for printing engine identification plates (to be used with 99378100)
	
<b>99378106</b>	Punches ( <b>F</b> ) for printing engine identification plates (to be used with 99378100)
	
<b>99389834</b>	Dynamometric screwdriver to calibrate screws for injector solenoid valve
	
<b>99390310</b>	Valve guide sleeker
	

**TOOLS**

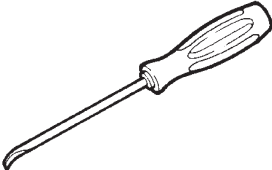
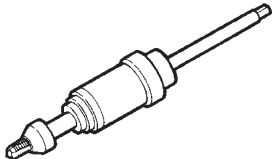
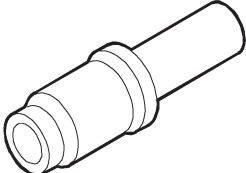
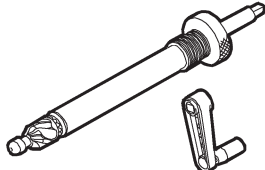
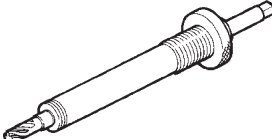
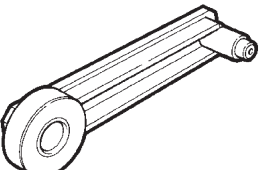
Tool No.	Description
<b>99390772</b>	Tool to remove residues from injector holder
	
<b>99390804</b>	Tool to thread injector holders to be extracted
	
<b>99394014</b>	Guide bush (to be used with 99394041 or 99394043)
	
<b>99394041</b>	Cutter to rectify injector holder housing (to be used with 99394015)
	
<b>99394043</b>	Reamer to rectify injector holder lower side (to be used with 99394015)
	
<b>99395215</b>	Gauge for centre distance check between camshaft and idle gear
	

## TOOLS

Tool No.	Description
99395216	Measuring pair for angular tightening with 1/2" and 3/4" square couplings
99395363	Complete square to check connecting rod squaring
99395603	Dial gauge (0 - 5 mm)
99395687	Reaming gauge (50 - 178 mm)
99396033	Centering ring of crankshaft front cap
8093731	Tester PT-01