

USE AND MAINTENANCE
USO E MANUTENZIONE
UTILISATION ET ENTRETIEN
BETRIEB UND WARTUNG
USO Y MANTENIMIENTO

MARINE ENGINES

NEF SERIES

MECHANICAL INJECTION SYSTEM

Publication edited by
Marketing - Adv. & Promotion
Print L31900007 - 10/05

**IVECO
MOTORS**



NEF SERIES

MECHANICAL INJECTION SYSTEM

N45 MNA M10.00

N67 MNA M15.00

N67 MNT M28.10

YEAR 2005

USE AND MAINTENANCE

INTRODUCTION

We would like to thank you for buying an IVECO MOTORS product, and compliment you on your choice of engine.

Before you carry out any operation involving the engine or its fittings, please read the contents of this manual carefully; compliance with the instructions provided in the manual is the best way to guarantee trouble-free, long term operation of the engine.

The contents of this manual refer to the standard configuration of the engine, and the illustrations are purely indicative. Some instructions are provided by giving the sequence of operations to be carried out in order to allow the engine and/or its fittings to perform in a certain way. In some cases they will be dependent on the configuration of the commands and the set-up of the vessel on which the engine is installed; for any points that differ from the contents of this manual, please consult the instructions provided by the Boatbuilder or a specific manual.

The information provided below was current at the date of publication.

The Manufacturer reserves the right to make modifications at any time without prior notice, for technical or commercial reasons or to update the engines to comply with legal requirements in the various Countries.

The Manufacturer declines all liability for any errors or omissions.

Please remember that the IVECO MOTORS Technical Service Network is available to offer you its experience and professional skills, wherever you may be.

CONTENTS

Page

■ GENERAL INFORMATION	3
Guarantee	3
Spare Parts	3
Liability	3
Safety	3
Engine technical data N45 MNA M10	4
Engine technical data N67 MNA M15	6
Engine technical data N67 MNT M28	8
Signs	10
■ USE	11
Preliminary checks	11
Starting and stopping the engine	11
Starting and stopping the engine from the analogue control panel ..	12
Recognising alarms	15
For proper use of the engine	16
Special warnings	16
Running in	17
Refuelling	18
■ CONTROLS AND MAINTENANCE	19
Maintenance personnel	19
Accident prevention	19
Frequency	20
Requirements	22
How to proceed	22
Moving the engine	29
Disposal of waste	30
■ LONG PERIODS OF INACTIVITY	31
Preparing the engine for a long period of inactivity	31
Restarting the engine after a long period of inactivity	32
■ EMERGENCIES ON BOARD	33

Page

■ IN APPENDIX	
Oil viscosity level according to surrounding temperatures	

■ GENERAL INFORMATION

GUARANTEE

In order to ensure that your engine gives the best possible performance and to take advantage of the IVECO MOTORS guarantee, you must follow the indications provided in this publication with great care; failure to do so may result in invalidation of the guarantee.

SPARE PARTS

Always use Original IVECO MOTORS Spare parts. This is essential to keep the engine in original running order.

The use of non-original spare parts will not only invalidate the guarantee, but will mean that IVECO MOTORS will not be considered liable in any way during the whole working life of the engine.

LIABILITY

The Manufacturer will only be considered liable subject to performance of the control and maintenance operations indicated and described in this manual; to this effect, proof that these operations have been performed must be provided. Any special maintenance operations that may be necessary must be carried out by qualified technicians from authorised Workshops in the IVECO MOTORS Network, using the instruments and equipment provided for the purpose.

SAFETY

The following information is intended to encourage caution when using the engine, so as to avoid damage to persons or property as a result of improper or incorrect behaviour.

- ❑ The engines must only be used for the purposes indicated by the Manufacturer.
- ❑ Any tampering, modification and use of non-original spare parts may compromise proper operation of the engine and safe navigation; **never, under any circumstances** make modifications to the wiring and to the units equipping the engine, or connect them to other power systems.
- ❑ The engine has moving parts, parts operating at high temperatures and other parts containing pressurised fluids; its electrical equipment houses electrical currents and voltage.
- ❑ The exhaust fumes produced by the engine are bad for your health.
- ❑ The engine must only be moved using suitable lifting tackle, making use of the U-bolts provided on the engine for that purpose.
- ❑ The engine must not be started up and used until the vessel in which it installed has satisfied all necessary safety requirements, or until the vessel has been guaranteed to comply with local laws and regulations.
- ❑ The operations required to guarantee the best possible use and preservation of the engine must only be carried out by persons of proven experience, equipment with tools considered suitable by IVECO MOTORS.

For the purpose of safety, further recommendations are given in the chapter CONTROLS AND MAINTENANCE.

ENGINE TECHNICAL DATA N45 MNA M10

The technical code and serial number are indicated on the rating plate, which is located on different parts of the engine, according to the model: flywheel casing, tappet cover, coolant tank.

Commercial code	N45 MNA M10
Engine family	F4
Cycle	4-stroke diesel
Number and arrangement of cylinders	4, in line
Bore x stroke	104 x 132 mm
Total displacement	4,480 cm ³
Air system	Natural aspiration (NA)
Injection type	Direct with VE rotating pump
Engine direction of rotation	Anticlockwise (seen from flywheel side)
Dry weight	495 kg

Electrical system	12 V (24 V on request)
Accumulator/s	
- capacity	180 Ah or above
- discharge current	800 A or above

Available settings (*)	N45 MNA M10
A1	74 kW (100 CV) @ 2800 rpm
B	66.5 kW (90 CV) @ 2800 rpm
C	63 kW (85 CV) @ 2800 rpm
D	63 kW (85 CV) @ 2800 rpm

(*) Maximum net power to the flywheel in compliance with ISO 3046-1.
Test conditions: T 25 °C; atmospheric pressure 100 kPa; relative humidity 30%.

WARNING

Any alteration of the above mentioned characteristics, in particular modification of the calibration of the injection system or the characteristics of the engine and its fittings, is strictly prohibited, penalty invalidation of the guarantee and absence of all liability on the part of IVECO MOTORS.

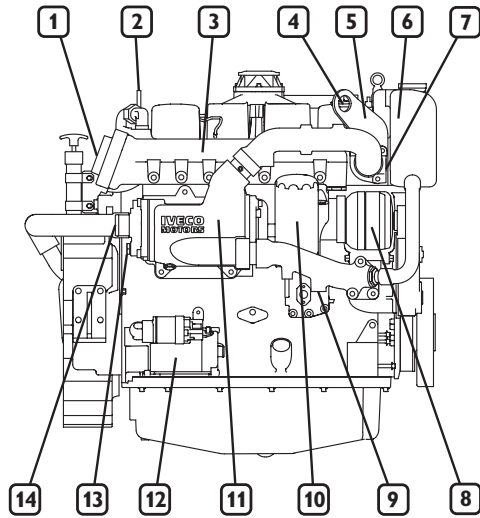

04_365_N

Engine N45 MNA M10

1. Exhaust gas discharge - 2. Lifting U-bolt - 3. Exhaust manifold - 4. Oil filler cap - 5. Lifting U-bolt - 6. Coolant tank- 7. Thermostat valve location - 8. Alternator - 9. Water-heater system tap or coolant drainage plug - 10. Oil filter - 11. Engine coolant-sea water heat exchanger - 12. Starter motor - 13. Removable anode. 14. Sea-water outlet manifold.

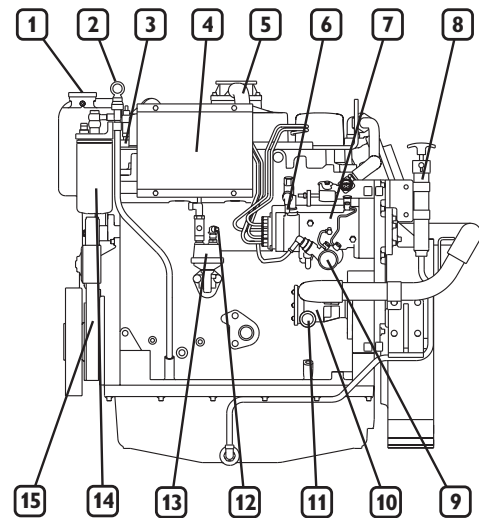

04_366_N

Engine N40 ENT M10

1. Coolant tank pressurisation cap - 2. Oil dipstick - 3. Water-heater system manifold - 4. Air filter - 5. Oil vapour recirculation - 6. Fuel outlet towards the tank - 7. Injection pump - 8. Oil extraction pump - 9. Cold injection timing regulator (KSB) - 10. Sea water pump - 11. Sea water pump inlet - 12. Fuel inlet from tank - 13. Fuel transfer pump - 14. Fuel filter - 15. Auxiliary member drive belt.

ENGINE TECHNICAL DATA N67 MNA M15

The technical code and serial number are indicated on the rating plate, which is located on different parts of the engine, according to the model: flywheel casing, tappet cover, coolant tank.

Commercial code	N67 MNA M15
Engine family	F4
Cycle	4-stroke diesel
Number and arrangement of cylinders	6, in line
Bore x stroke	104 x 132 mm
Total displacement	6,700 cm ³
Air system	Natural aspiration (NA)
Injection type	Direct with VE rotating pump
Engine direction of rotation	Anticlockwise (seen from flywheel side)
Dry weight	600 kg

Electrical system	12 V (24 V on request)
Accumulator/s	
- capacity	180 Ah or above
- discharge current	800 A or above

Available settings (*)	N67 MNA M15
A1	110 kW (150 CV) @ 2800 rpm
B	99.5 kW (135 CV) @ 2800 rpm
C	92 kW (125 CV) @ 2800 rpm
D	92 kW (125 CV) @ 2800 rpm

(*) Maximum net power to the flywheel in compliance with ISO 3046-1. Test conditions: T 25 °C; atmospheric pressure 100 kPa; relative humidity 30%.

WARNING
<i>Any alteration of the above mentioned characteristics, in particular modification of the calibration of the injection system or the characteristics of the engine and its fittings, is strictly prohibited, penalty invalidation of the guarantee and absence of all liability on the part of IVECO MOTORS.</i>

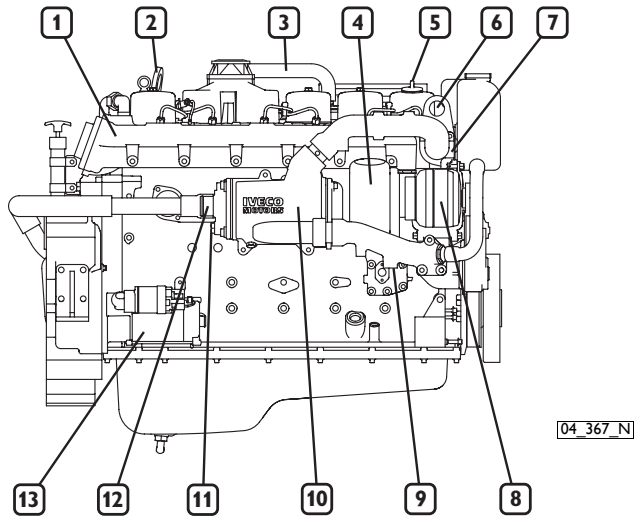

Engine N67 MNA M15

1. Exhaust gas manifold - 2. Lifting U-bolt - 3. Oil vapour recirculation - 4. Oil filter - 5. Oil filler cap - 6. Lifting U-bolt - 7. Thermostat valve location - 8. Alternator - 9. Water-heater system tap or coolant drainage plug - 10. Engine coolant-sea water heat exchanger - 11. Removable anode - 12. Sea-water outlet manifold - 13. Starter motor.

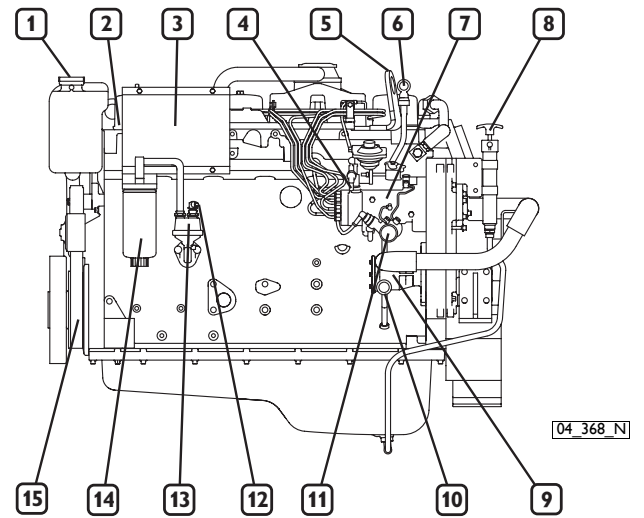

Engine N67 MNA M15

1. Coolant tank pressurisation cap - 2. Water-heater system manifold - 3. Air filter - 4. Fuel outlet towards the tank - 5. Lifting U-bolt - 6. Oil dipstick - 7. Injection pump - 8. Oil extraction pump - 9. Sea water pump - 10. Sea water pump inlet - 11. Cold injection timing regulator (KSB) - 12. Fuel inlet from tank - 13. Fuel transfer pump - 14. Fuel filter - 15. Auxiliary member drive belt.

ENGINE TECHNICAL DATA N67 MNT M28

The technical code and serial number are indicated on the rating plate, which is located on different parts of the engine, according to the model: flywheel casing, tappet cover, coolant tank.

Commercial code	N67 MNT M28
Engine family	F4
Cycle	4-stroke diesel
Number and arrangement of cylinders	6, in line
Bore x stroke	104 x 132 mm
Total displacement	6,700 cm ³
Air system	Supercharged and aftercooled
Injection type	Direct with VE rotating pump
Engine direction of rotation	Anticlockwise (seen from flywheel side)
Dry weight	600 kg

Electrical system	12 V (24 V on request)
Accumulator/s	
- capacity	180 Ah or above
- discharge current	800 A or above

Available settings (*)	N67 MNT M28
A1	206 kW (280 CV) @ 2800 rpm
B	191 kW (260 CV) @ 2800 rpm
C	169 kW (230 CV)@ 2800 rpm
D	132 kW (180 CP)@ 2500 rpm

(*) Maximum net power to the flywheel in compliance with ISO 3046-1.
Test conditions: T 25 °C; atmospheric pressure 100 kPa; relative humidity 30%.

WARNING
<i>Any alteration of the above mentioned characteristics, in particular modification of the calibration of the injection system or the characteristics of the engine and its fittings, is strictly prohibited, penalty invalidation of the guarantee and absence of all liability on the part of IVECO MOTORS.</i>

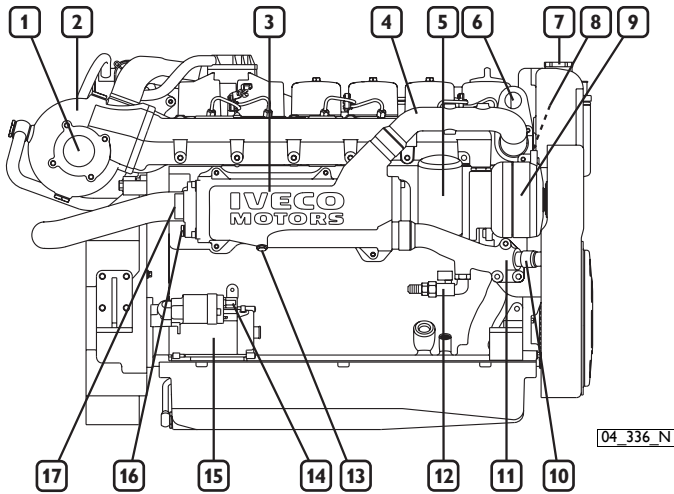

Engine N67 MNT M28

1. Exhaust gas discharge - 2. Turbocharger - 3. Engine coolant-sea water heat exchanger - 4. Coolant outlet manifold from engine - 5. Oil filter - 6. Lifting U-bolt - 7. Coolant filler cap - 8. Location of thermostat valve - 9. Alternator - 10. Manifold connecting to coolant tank - 11. Coolant infeed to engine - 12. Water-heater system tap or plug - 13. Coolant drainage plug - 14. Connection to battery positive terminal - 15. Electrical starter motor - 16. Removable anode - 17. Sea-water outlet manifold.

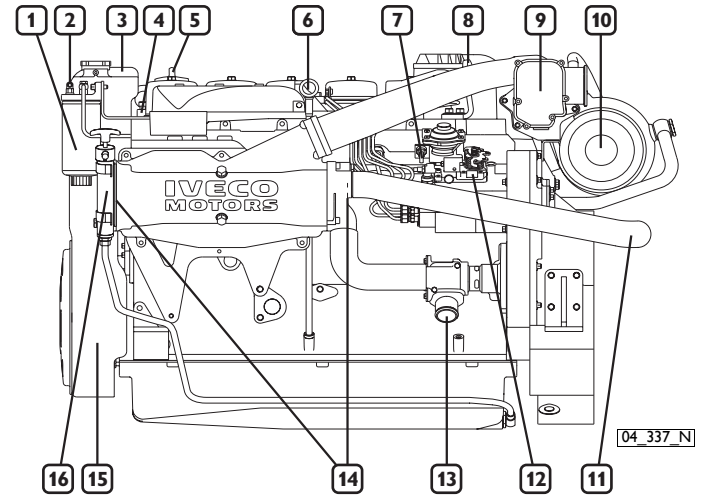

Engine N67 MNT M28

1. Fuel filter - 2. Fuel inlet from tank - 3. Coolant tank - 4. Location of water-heater system manifold or plug - 5. Oil filler cap - 6. Oil dipstick - 7. Fuel outlet towards the tank - 8. Lifting U-bolt - 9. Oil vapour filter - 10. Air filter - 11. Sea water connector pipe - 12. Injection pump - 13. Sea water pump inlet - 14. Removable anode - 15. Auxiliary member pulley casing - 16. Oil extraction pump.

SIGNS

Certain warning signs are affixed to the engine by the boatbuilders, and their meanings are indicated below.

NOTE: The signs with an exclamation mark on them underline a potential **danger**.



Lifting point (engine only).



Fuel Cap
(on the fuel tank, if there is one).



Oil Cap.



Oil dipstick.



Danger of burning:
Expulsion of hot water under pressure.



Danger of burning:
Presence of high temperature parts.



Danger of fire:
Fuel present.

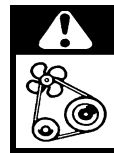

Danger of impact or catching
on moving parts:
Presence of fans, pulleys, belts or the like.

■ USE

PRELIMINARY CHECKS

Before starting the engine each time:

- ❑ Make sure that the sea-water inlet valve is open. Operation of the sea water pump without water would cause irreparable damage to the internal rotor within a very few seconds.
- ❑ Check the level of technical fluids (fuel, engine oil and coolant).

CAUTION!



Before starting the engine, make sure that no combustible vapours or gasses are present in the engineroom.

STARTING AND STOPPING THE ENGINE

For vessels equipped with instrument panels that are not manufactured by IVECO MOTORS

The start-up and shut-down operations described below apply to an on-board control panel manufactured by IVECO MOTORS; if the vessel is fitted with an instrument panel that has been customised by the Boatbuilder or Fitter, these operations may vary according to the various choices made during construction. In these cases, follow the start-up/shut-down sequence and use the instrument panel description provided by the Boatbuilder on specific documentation.

STARTING AND STOPPING THE ENGINE FROM THE ANALOGUE CONTROL PANEL

Procedure for start-up from the main IVECO MOTORS control panel (supplied on demand)

1. Lift the protective cover over the key switch (8), insert the key and turn it to the right to position **8B**.
2. Make sure that the analogue instruments are showing values that conform with the relevant physical parameters (temperature, battery voltage and oil pressure).
3. Wait for the beeper to stop sounding and for the alarm indicator lights on the indicator module (5) to switch off, with the exception of the "alternator malfunction" and "low oil pressure" indicators. At the same time, check that the indicator test has been performed successfully (information on how to interpret this test and indications on the module are given in the relevant paragraph).
4. Turn the key to position **8C**; once the engine has started, release the key quickly and do not accelerate.
5. Make sure that the analogue instruments are showing values that conform with the relevant physical parameters (temperature, battery voltage and oil pressure).
6. If the engine does not start, after releasing the key it will only be possible to turn it back to the start position after first returning the switch to the rest position **8A**.

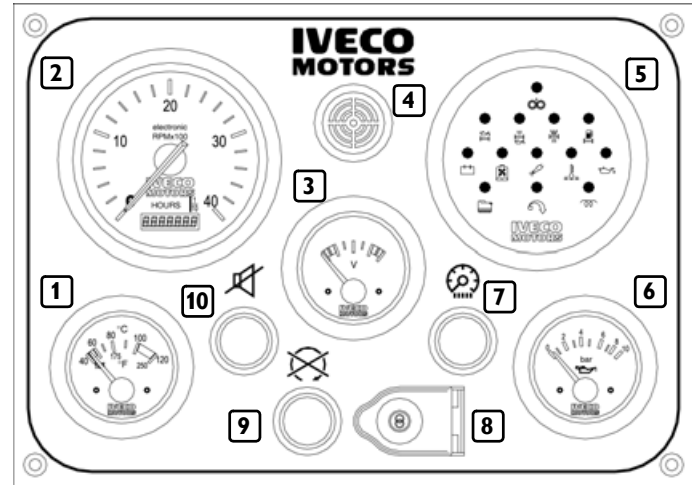

04_354_N

1. Coolant temperature indicator - 2. Rev counter and hour counter - 3. Voltmeter - 4. Beeper - 5. Indicator and alarm module - 6. Engine oil pressure indicator - 7. Control panel instrument light switch - 8. Key switch to start/stop the engine - 9. Button to stop the engine - 10. Button to disable the beeper.

Detail of the key switch

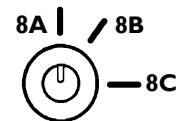

04_356_N

Procedure for start-up from IVECO MOTORS secondary or fly-bridge control panel (supplied on demand)

- 1 **Enable the secondary control panel, by turning the key switch on the main panel to position 8B.**
2. Wait for the beeper to stop sounding and for the alarm indicators on the indicator module (5) to switch off, with the exception of the "alternator recharge" and "low oil pressure" indicators. At the same time, check that the indicator test has been performed successfully (information on how to interpret this test and indications on the module are given in the relevant paragraph).
3. Press the green button (5) and release it when the engine has started.
4. Check that the rev indicator shows a plausible value.

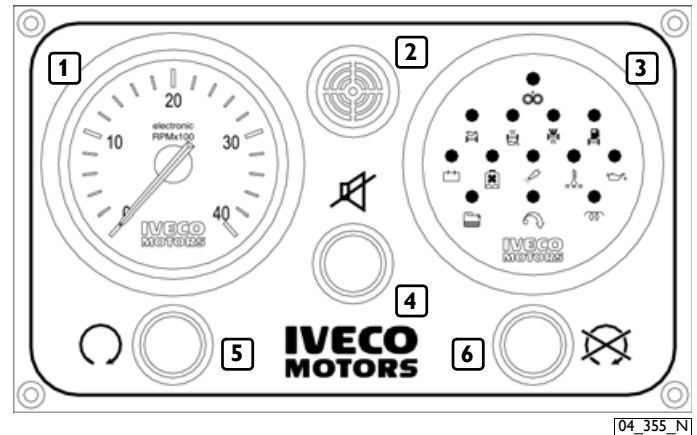

1. Rev counter and hour counter - 2. Beeper - 3. Indicator and alarm module - 4. Button to disable the beeper - 5. Engine start button - 6. Engine stop button.

Stopping the engine

Before stopping the engine it is recommended you run it for a few minutes at minimum speed with no load; this will allow the temperature to drop evenly and will avoid harmful thermal shocks.

- A. The engine is normally stopped from the main IVECO MOTORS control panel by turning the key switch to the rest position **8A** or by turning a similar command on the customised control panel.
- B. The IVECO MOTORS secondary control panel is stopped by pressing the red button (6) on the control panel.

The main IVECO MOTORS control panel for engines equipped with an “**excited**” device (on request or as prescribed by the Certification Body), is stopped by pressing the red button (9).

To re-start the engine from the main control panel:

1. Return the key switch to the rest position **8A** to reset all the on-board control panel functions.
2. Proceed as described.

To re-start the engine from the secondary control panel:

1. Make sure that the panel has been enabled (key switch on the main control panel turned to position **8B**).
2. Press the green button (5) and release it when the engine has started, making sure that the rev indicator is showing a plausible reading.

RECOGNISING ALARMS

IVECO MOTORS on-board control panels with analogue instruments are fitted with an electronic module that includes the indicator lights and the interface, timer and alarm storage circuits.

The figure illustrates the dial and the key indicates the meaning of the alarm signals sent by all the indicator lights; some types of engine and relevant equipment only make some of the above mentioned functions available.

If the Boatyard uses different technical options there may also be changes to the above.

Operation

When the key switch is turned to position **8B** the signals and alarms module will perform an efficiency test on all the indicator lights, lasting 5 seconds, with the exception of the "Pre-lubrication", "Pre-post heating", "EDG system malfunction" indicators, and simultaneously the beeper sounds.

It is possible to stop the beeper before the end of the test, by pressing the relevant button.

During start-up and for the following 15 seconds, all alarm functions are disabled; after this period, each alarm detected by the sensors provided on the engine will result in the relevant indicator flashing and a simultaneous warning sound from the beeper. If the beeper is disabled by pressing the relevant button, the indicator light will turn on without flashing and the alarm will be stored until the engine is next stopped.

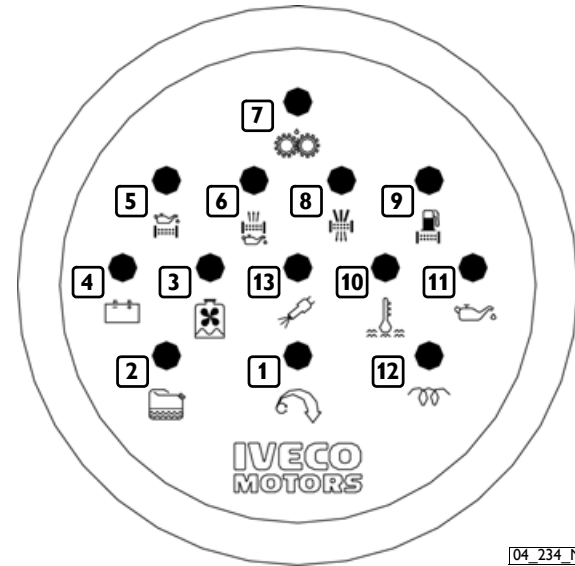

[04_234_N]

1. Maximum allowed rotation speed exceeded (on request) - 2.
- Water in the fuel pre-filter - *
3. Engine coolant level low - 4.
- Alternator malfunction - *
5. Oil filter blocked - *
6. Oil vapour filter blocked - *
7. Pre-lubrication in progress - 8.
- Air filter blocked - *
9. Fuel filter blocked - 10.
- Coolant temperature high - 11.
- Oil pressure low - *
12. Pre-post heating - *
13. Malfunction in EDC electronic injection system.

*Alarm functions not available with standard setup.

FOR PROPER USE OF THE ENGINE

- ❑ Do not continue to press the starter, when the engine has started.
- ❑ Do not remain in dock while waiting for the engine to warm up, but after starting, commence navigation at low speed; the working temperature will be reached properly with the engine running at medium speeds.
- ❑ Do not operate the engine at minimum speed for long periods, as this encourages the production of harmful exhaust and does not guarantee optimum performance.
- ❑ The engine speed must be increased and decreased gradually, to allow regular combustion and proper operation of all engine components; sudden acceleration may result in very smokey exhaust.
- ❑ The maximum cruising speed must not be more than 90% of the speed corresponding to maximum power (see ENGINE TECHNICAL DATA).
- ❑ During navigation, check that:
 - The engine coolant temperature does not reach the alarm threshold.
 - The oil pressure remains within normal values.

SPECIAL WARNINGS

Coolant temperature high

If the temperature indicated on the instrument is considered too high, or if the alarm is displayed, reduce speed and return to port to check the state of the sea water intake and cooling system circuits; also check and have checked:

- tension of the water pump and alternator command belts.
- operation of the thermostat valve.
- whether or not the heat exchangers are clean.

CAUTION!



When the engine is warm, a pressure liable to cause hot liquid to be expelled with extreme violence is created within the cooling circuits. This results in a danger of burning. Only open the coolant tank cap if strictly necessary, and only when the engine is cold.

Low lubricant pressure

If the pressure indicated by the instrument is considered insufficient, or if the "low oil pressure" indicator lights up, stop the engine and check the oil level. Top up if necessary (see CONTROL AND MAINTENANCE section).

If the condition persists, return to port at low speed and contact an Authorised Service Centre.

Water in the fuel pre-filter

It is a good rule to drain the water from the filters, before the relevant indicator comes on.

Avoid using the engine with the fuel tank only a small reserve of fuel; this encourages the formation of condensation and makes it more likely you will suck up dirt or air, resulting in engine stoppage.

CAUTION!



When refuelling, always pay great care to ensure that no solid or liquid pollutants enter the fuel tank; you must also remember that smoking and live flames are prohibited when refuelling.

Air filter blocked and exhaust circuit inefficient

Inspect the cleanliness of the air intakes and discharge pipes on a regular basis. The maintenance intervals indicated in this manual only take into account the performance of engine components, and not any additional fittings installed by the Boatbuilder and any external events.

CAUTION!



Visually check that the exhaust circuit is not blocked or damaged, so as to prevent dangerous fumes within the vessel.

Alternator malfunction

Check it or have it checked periodically for cleanliness, wear and proper tensioning of the drive belt.

CAUTION!



The drive members are located under protective casings. These must only be removed when the engine is not turning.

Irregularities in the electrical system

Periodically check, particularly during the winter, to ensure that the batteries are clean and in full working order, checking and topping up as indicated in the section CONTROLS AND MAINTENANCE; always comply with the WARNINGS provided. Should it be necessary to replace the batteries, always comply with the characteristics indicated in the section ENGINE TECHNICAL DATA.

RUNNING IN

Thanks to modern engine construction technology, no particular running in procedure is required. However, it is recommended that, for the first 50 hours, you do not use the engine at high power for long periods.

REFUELLING

Parts to be supplied	N45 MNA M10 litres (kg)	N67 MNA M15 litres (kg)	N67 MNT M28 litres (kg)
Cooling circuit ⁽¹⁾	21	22.5	24.5
Lubrication circuit ⁽²⁾ total capacity ⁽³⁾	11.5 (10.5)	16.5 (15)	16.5 (15)
Periodic changing:			
oil sump at minimum level	7.7 (7)	9 (8)	9 (8)
oil sump at maximum level	9.9 (9)	14.5 (13)	14.5 (13)
Fuel tank ⁽⁴⁾	-	-	-

(1) Use a mixture of water and 50% PARAFU 11 even during the summer months. As an alternative to PARAFU 11, you can use another product that complies with international specifications SAE J 1034.

(2) Use lubricants that comply with international specifications ACEA E3 - E5 (high power engines), API CF - CH4 (associated with fuels with a percentage sulphur < 0.5%), MIL - L - 2104 F.

Oil consumption is considered acceptable when it reaches a maximum of 0.5% of fuel consumption.

(3) The amounts indicated refer to initial refuelling, and include filling the engine, sump and filter.

(4) Only use normal commercial diesel fuel (EN590 standards). Do not use additives. Do not use fuels derived from the synthesis of organic substances and vegetable oils (Biodiesel).

WARNING

Refuelling from drums or tanks may result in pollution of the diesel fuel, with the risk of damage to the injection system; if necessary, filter the fuel in a suitable manner or allow sedimentation of the impurities before refuelling.

Low temperature diesel

EN590 specifications distinguish different classes of diesel fuel, identifying the characteristics of those best suited to low temperatures. It is entirely up to the Oil companies to comply with these regulations, which foresee that fuels suited to the climatic and geographic conditions of the various Countries be distributed.

Filling up with marine gear oil

For the amount and types of oil to be used in the marine gear, please see the manual provided by the Manufacturer.

■ CONTROLS AND MAINTENANCE

MAINTENANCE PERSONNEL

The engine control and maintenance operations described in the following chapter require training, experience and compliance with current safety regulations; for this reason they must be carried out by special technicians, as indicated below.

❑ **Controls:** by workshop technicians or the vessel user if necessary.

❑ **Periodic maintenance:** by qualified personnel equipped with suitable equipment and adequate means of protection. Operations marked by the key symbol (see illustration).



❑ **Special maintenance:** by qualified Authorised Service Centre staff with specific technical information and equipment. Operations marked by the key symbol (see illustration).



The Authorised Service Centres are the ones in the IVECO MOTORS Technical Service Network.

ACCIDENT PREVENTION

- ❑ Always wear heavy-duty footwear and overalls.
- ❑ Never wear loose, flapping garments, rings, bracelets and/or necklaces in the vicinity of engines or moving parts.
- ❑ Always wear protective gloves and goggles when:

- filling up batteries with acid solution
 - refuelling with inhibitors or antifreeze
 - replacing or topping up lubricant (hot engine oil may cause burns and scalds. Only carry out these operations when the oil has dropped to a temperature of below 50°C).
- ❑ When working in the engine compartment, pay particular attention to how you move, to avoid contact with moving parts or high temperature components.
 - ❑ Wear goggles and use high pressure air jets (maximum air pressure used to clean is 200 kPa (2 bar, 30 psi, 2 kg/cm²).
 - ❑ Wear a protective helmet when working in an area where there are suspended loads or systems installed at head-height.
 - ❑ Use protective hand cremes.
 - ❑ Immediately replace wet overalls.
 - ❑ Always keep the engine clean, removing oil, grease and coolant stains.
 - ❑ Store cloths in flame-proof containers.
 - ❑ Do not leave foreign bodies on the engine.
 - ❑ Use suitable, safe containers for used oil.
 - ❑ When completing a repair, make suitable provisions to stop the engine taking in air if, after start-up, an uncontrolled increase in engine speed were to occur.

CAUTION!



Do not carry out maintenance operations when the electric power supply is turned on: always check to ensure that the appliances are properly earthed. During diagnosis and maintenance operations, make sure that your hands and feet are dry, and whenever possible use insulating stands.

FREQUENCY

Controls	Frequency
Check oil level in engine	Daily
Check oil level in marine gear	Daily
Check engine coolant level	Daily
Check exhaust pipe/s for damage	Daily
Drain water from the fuel filter or pre-filter	150 hours ⁽¹⁾
Check/top up electrolyte level in batteries and clean terminals	Half-yearly

The maintenance intervals indicated below take into account the typical working factors for various types of engine use; the most suitable interval for maintenance operations for the various applications will be indicated by the maintenance staff, according to the way and working conditions in which the engine is used.



Planned maintenance

Frequency

Clean air filter/s	300 hours ^{(2) (7)}
Check corrosion of zinc anodes	300 hours ^{(4) (7)}
Check state of oil vapour filter (for engine N67 MNT M28)	300 hours ⁽⁷⁾
Drain/suck condensation from fuel tank/s	300 hours ^{(1) (7)}
Replace engine oil	600 hours ^{(5) (7)}
Change oil filter/s	600 hours ^{(5) (7) (8)}
Change fuel filter/s	600 hours ^{(1) (7) (8)}
Change fuel pre-filter	600 hours ^{(1) (7)}
Change oil in the marine gear	see relevant details
Inspect sea chest	yearly
Check tension and state of belt	yearly ⁽³⁾
Change coolant	1200 hours or 2 years
Change air filter	2 years
Change oil vapour filter (for engine N67 MNT M28)	2 years ⁽⁵⁾



Special maintenance

Frequency

Check wear in sea water pump rotor	900 hours
Change auxiliary member belt	1200 hours or 2 years
Clean heat exchangers	2 years ⁽⁶⁾
Clean the turbocharger	2 years ⁽⁵⁾
Injector calibration	1800 hours
Overhaul injection pump	3000 hours
Adjust play in valves-rocker arms	3000 hours

- 1) Maximum period when using good quality fuel, (EN 590 standard); this is reduced if the fuel is contaminated and alarms are triggered due to blockage of the filters and presence of water in the pre-filter. When blockage of the filter is indicated, it must be replaced. If the water in pre-filter indicator does not go out after drainage, the pre-filter must be replaced
- 2) The frequency with which operations are carried out will depend on the working conditions and efficiency/wear of the product. If the engine is not used for long periods of time, check it before you start it.
- 3) Refers to engines with traditional and automatic tensioning devices.
- 4) The anode must be replaced if corrosion has exceeded 50% of the volume of zinc.

- 5) Replace lubricants according to the frequency indicated in the REFUELLING table.
- 6) Sea water/combustion air heat exchanger: clean both the air and water sections; engine coolant/sea water heat exchanger: clean the sea water section; optional sea water/marine gear oil heat exchanger: clean the sea water section.
- 7) Must be performed annually, even if the required number of working hours are not reached.
- 8) Only use filters with the following characteristics:
 - filtration level $< 12 \mu\text{m}$
 - filtering efficiency $\beta > 200$.

WARNING

When using fuel with a percentage sulphur exceeding 0.5%, or when using oils that do not comply with the specifications provided in the refuelling table, the times at which the engine oil, engine oil filter and oil vapour filter must be changed will vary according to the use and working conditions of the engine itself; for further information, please consult the technicians responsible for maintenance.

REQUIREMENTS

1. Do not disconnect the batteries with the engine running.
2. Do not carry out arc welding operations in the vicinity of the engine without first removing electrical cables.
3. After each maintenance operation involving disconnection of the battery/batteries, make sure that the terminals have been properly locked onto the poles.
4. Do not use battery chargers to start the engine.
5. Disconnect the on-board network battery/batteries when recharging.
6. Do not paint the appliances, components and electrical connectors equipping the engine.
7. Disconnect the battery/batteries before any electrical operations.
8. Contact the Boatyard before installing electronic equipment on board (two-way radios, echo-sounding equipment, etc.).

HOW TO PROCEED

Check oil level in engine

Only proceed with the engine stopped and at a low temperature, so as to avoid the risk of burning.

- Using the dipstick (1), check that the oil level is between the "Min" and "Max" levels.
- If the level is too low, top up through the inlet on the cylinder head, after first removing the relevant cap (2).

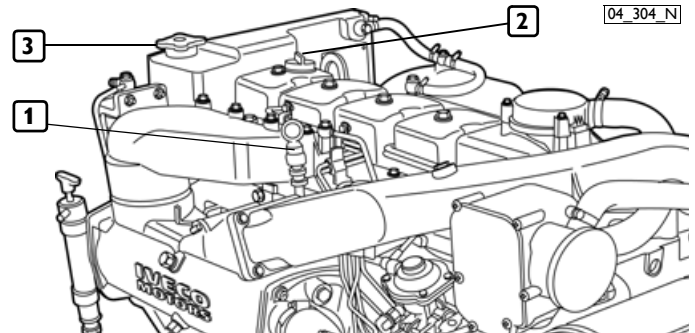

WARNING

- After topping up, make sure that the oil level does not exceed the "Max" limit marked on the dipstick.
- Make sure that the dipstick is inserted properly and the filler cap is turned in a clockwise direction until it stops turning completely.

Check oil level in marine gear

Check the oil level in the marine gear following the indications provided in the marine gear Manufacturer's manual.

Check coolant level

Only proceed with the engine stopped and at a low temperature, so as to avoid the risk of burning.

- ❑ Remove the loading tank pressurisation cap (3 - previous page).
- ❑ Visually check the coolant level.
- ❑ Top up the tank if necessary, using a mixture of 50% clean water (not distilled) and Parafì 11 (see REFUELLING table).

CAUTION!



Only open the coolant tank cap when the engine is cold.

Check exhaust pipe/s for damage

Visually check that the exhaust system is not blocked or damaged.

- ❑ Make sure that there is no risk of dangerous fumes within the vessel. Contact the Boatyard if necessary.

Draining water from the fuel filter of pre-filter

The high risk of refuelling with fuel that is polluted by foreign bodies and water means that it is necessary to perform this control even if no alarm is shown on the on-board control panel.

Proceed with the engine stopped.

- ❑ Place a container under the filter or pre-filter to collect the fluid.
- ❑ Unscrew the tap plug (1) in the bottom part of the filter or pre-filter; in some lay-outs the plug includes a sensor to detect the presence of water in the diesel.
- ❑ Drain off liquid until only "diesel" can be seen".
- ❑ Close the plug again, tightening it completely by hand.
- ❑ Dispose of the drained fluids according to current requirements.

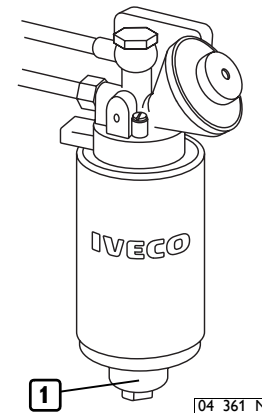

Checking the level of electrolyte solution in the batteries

Place the batteries on a level surface, then proceed as follows.

- ❑ Visually check that the fluid level is between the "Min" and "Max" limits; in the absence of references, check that the fluid covers the Lead plates inside the elements by approximately 5 mm.
- ❑ If necessary, top up with distilled water only those elements in which the level is below minimum.
- ❑ Contact specialised technical staff if the battery needs recharging.

- ❑ Have the efficiency of the battery recharging system tested if a voltage of less than 11 V (for 12 V rated systems) or 22 V (for 24 V rated systems) is detected with the engine running.
- ❑ On this occasion, make sure that the terminals and clamps are clean, properly locked and protected by vaseline.

CAUTION!



- ❑ *The batteries contain sulphuric acid, which is extremely caustic and corrosive; always wear protective gloves and goggles when topping them up. Whenever possible it is recommended that this control be carried out by specialised personnel.*
- ❑ *Do not smoke or use live flames near the batteries during controls, and make sure that the room you are working in is adequately ventilated.*

Some types of battery have a single cover for all the inspection plugs. To access the elements, use a lever as shown in the figure.

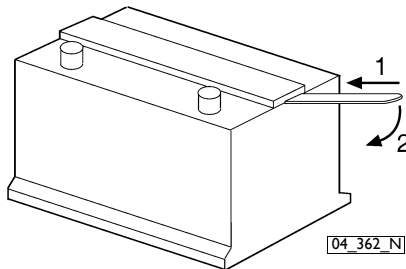

Cleaning the air filter

- ❑ Remove the filter by loosening the screws (4) indicated in the figure.
- ❑ Blow dehumidified compressed air through the filter element, from the inside outward (maximum pressure 200 kPa), or wash with water only, avoiding the use of detergents; **do not use diesel.**
- ❑ Replace the filter if any breakages are found.
- ❑ Replace the filter once every 2 years.
- ❑ Restore normal operating conditions after positioning the filter in its housing.

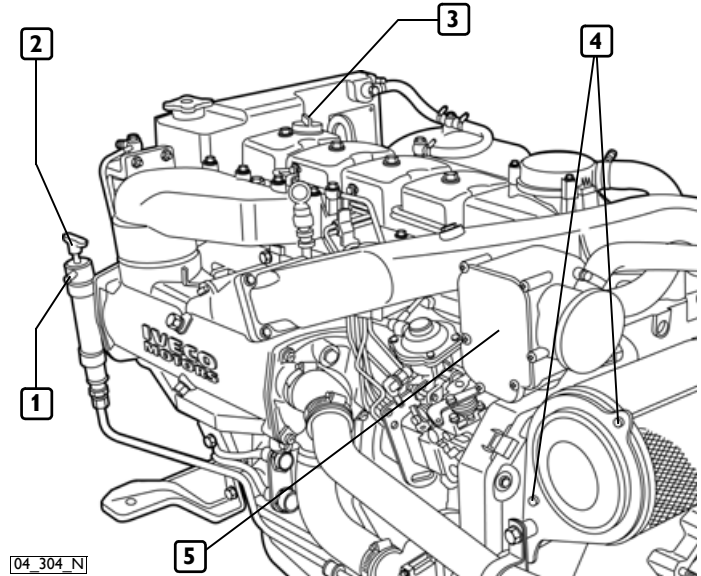

Check corrosion of zinc anodes

Only proceed with the engine stopped and at a low temperature:

- ❑ Provide suitable containers to ensure that no water is dispersed inside the vessel during removal of the anodes.
- ❑ Remove the anodes, unscrewing them from their housings (see location in the section ENGINE TECHNICAL DATA).
- ❑ Make sure that corrosion has not exceeded 50% of the volume of zinc. If this is the case, change them.
- ❑ Replace the anodes in their housings, locking them to the prescribed torque.

Check state of oil vapour filter (figure on page 24)

Required for engine N67 MNT M28

Only proceed with the engine stopped and at a low temperature, so as to avoid the risk of burning:

- ❑ Unfasten the screws and remove the cover (5) to the filter compartment.
- ❑ Remove the two filters and check them for deposits; if any deposits are found, replace them.
- ❑ Replace the cover in its housing.

Changing engine oil (figure on page 24)

Only proceed with the engine stopped and at a low temperature, so as to avoid the risk of burning.

- ❑ Place a container under the hand pump (1) outlet pipe (2), to collect the used oil.
- ❑ Unscrew the filler cap, turn the hand pump provided (2), which is set up to extract the oil only, until the oil sump is completely empty.
- ❑ Fill up with fresh oil through the feeder hole (3) on the timer cover, using the types and amounts of oil indicated in the table REFUELLING.
- ❑ Using the dipstick, check that the oil level is between the "Min" and "Max" levels.
- ❑ Dispose of used oil according to current requirements.

Changing the engine oil filter

Only proceed with the engine stopped and at a low temperature, so as to avoid the risk of burning.

Only use filters with a filtration level equivalent to the ones you are replacing (see section FREQUENCY).

- ❑ Place a container under the filter support (1), to collect the used oil.
- ❑ Unscrew the filter and remove it.
- ❑ Carefully clean the surfaces of the support that are in contact with the filter seal.
- ❑ Damp the new filter seal with a thin layer of oil.
- ❑ Hand screw the new filter into place until the seal gasket touches the support, then lock by a further 3/4 of a turn.
- ❑ Dispose of the old filter according to current requirements.

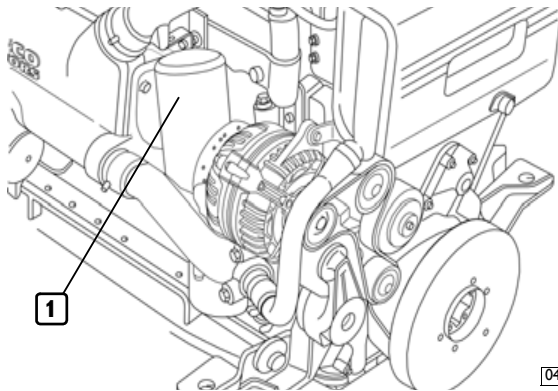

Changing the fuel filter

Only proceed with the engine stopped and at a low temperature.

Only use filters with a filtration level equivalent to the ones you are replacing (see section FREQUENCY).

- ❑ Remove the filter by unscrewing it.
- ❑ Check that the new filter has performance levels that satisfy the needs of the engine (e.g. by comparing them with the old one).
- ❑ Damp the new filter seal with diesel or engine oil.
- ❑ Hand screw the new filter into place until the seal gasket touches the support, then lock by a further 3/4 of a turn.

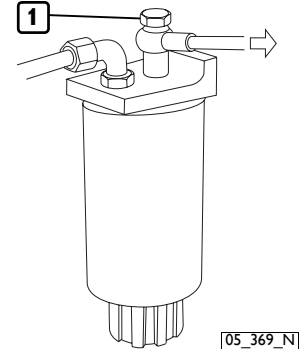

WARNING

Do not fill up the new filter before fitting it to the support, to avoid introducing harmful impurities into the injection system and circuit.

Bleeding procedure:

- ❑ Loosen the fuel outlet manifold, located on the upper part of the filter (1).
- ❑ Make sure that any diesel coming out will not dirty the auxiliary member drive belt or be dispersed into the environment.
- ❑ Use the pre-filter hand pump until the diesel coming out is free from any residual air.

- ❑ Lock the manifold loosened as above to the required torque.
- ❑ Dispose of any diesel expelled during the above operation.
- ❑ Start the engine and run it at minimum speed for a few minutes to eliminate any residual air.

NOTE: should it be necessary to accelerate the bleeding phase, the hand pump can be used during start-up.

Changing the fuel pre-filter

Only proceed with the engine stopped and at a low temperature.

- ❑ Remove the pre-filter by unscrewing it.
- ❑ Check that the new filter has performance levels that satisfy the needs of the engine (e.g. by comparing them with the old one).
- ❑ Damp the new filter seal with diesel or engine oil.
- ❑ Hand screw the new filter into place until the seal gasket touches the support, then lock by a further 3/4 of a turn.
- ❑ Bleed the system using the hand pump (1) as indicated when changing the filter, and also turning the bleeder screw on the pre-filter (2).
- ❑ Start the engine and run it at minimum speed for a few minutes to eliminate any residual air.

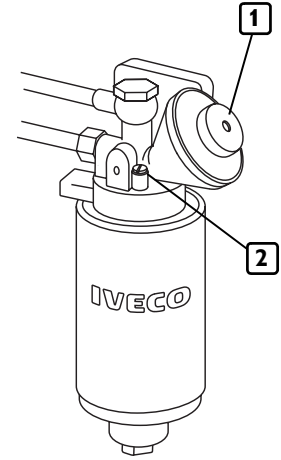

04_361_N

Check tension and state of the auxiliary member drive belt

Only proceed with the engine stopped and at a low temperature, so as to avoid the risk of burning.

- Remove the casing protecting the pulleys.
- Check that the pulleys are not torn or worn, and that there are no lubricants or fuel on them. If this is not the case, replace them.
- At the same time, make sure that the tensioning device is working properly, proceeding as indicated in the figure.
- Replace the guard casing in its housing, and lock all the seal elements.

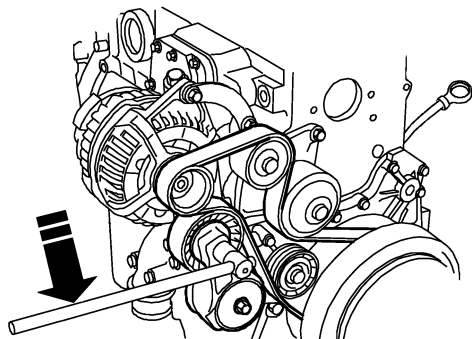

74178

Replace coolant

Only proceed with the engine stopped and at a low temperature, so as to avoid the risk of burning.

- Provide suitable containers to ensure that no coolant is dispersed into the environment.
- Remove the plugs on the circuit components and wait until the circuit has drained completely (the location of plugs is given in the section ENGINE TECHNICAL DATA). After emptying, replace the plugs in their housings, making sure that the seal rings are all undamaged.
- Fill up the circuit as indicated in the table REFUELLING.
- Bleed the circuit and top-up if necessary.

Change oil vapour filter (figure on page 24)

Only proceed with the engine stopped and at a low temperature, so as to avoid the risk of burning.

- Unfasten the screws and remove the cover (5) to the filter compartment.
- Remove the two filters, and dispose of them according to current requirements.
- Insert the new filters and replace the cover.



WARNING

The operations listed below must only be carried out by qualified staff from the IVECO MOTORS Service Centres or by staff from the Boatbuilders.

The methods used to perform them are described in the Technical and Repair Manuals.

Drain/suck water and condensation from tanks

Inspect sea chest

Check wear in sea water pump rotor

Clean heat exchangers

Clean the turbocharger

Injector calibration

Overhaul injection pump

Adjust play in valves-rocker arms

The method used to change the oil in the marine gear is indicated in the relevant documentation supplied by the Manufacturer of the marine gear itself.

MOVING THE ENGINE

The operations necessary to embark and disembark the engine must only be carried out by technicians from Authorised Service Centres.

When lifting the **engine only**, use the U-bolts indicated in this manual in the section ENGINE TECHNICAL DATA and marked on the engine with special stickers.

Lifting must be carried out using a rocker arm that keeps the metal cables supporting the engine parallel, using all the U-bolts provided simultaneously; the use of a single U-bolt only is not allowed.

The engine lifting system must have a capacity and size suited to the weight and dimensions of the engine; check that there is no interference between the lifting system and the engine components.

Do not lift the engine before removing the transmission members that are coupled to it.

DISPOSAL OF WASTE

The engine is made up of parts and elements that, if discarded, may cause damage to the environment.

The materials listed below must be handed over to specialised Collection Centres; the laws in force in the various Countries foresee severe penalties for transgressors:

- Starter batteries.
- Used lubricants.
- Mixtures of water and antifreeze.
- Filters.
- Additional cleaning materials (e.g. greasy or fuel-soaked cloths).

■ LONG PERIODS OF INACTIVITY

PREPARING THE ENGINE FOR A LONG PERIOD OF INACTIVITY

In order to prevent oxidation of the internal parts of the engine and of certain components in the injection system, when the engine is expected to be inoperative for periods of more than two months, the following operations must be carried out in preparation for this:

1. Drain the lubricant from the sump, after first warming up the engine.
2. Fill the engine with protective oil type 30/M (or alternatively oil that complies with MIL 2160B type 2 specifications), up to the "minimum" level indicated on the dipstick. Start the engine and keep it running for approximately 5 minutes.
3. Drain the fuel from the injection circuit, from the filter and from the injection pump pipes.
4. Connect the fuel circuit to a tank containing CFB (ISO 4113) protective fluid, and feed in the fluid by putting the circuit under pressure and running the engine for approximately 2 minutes, after first disabling the injection system. This operation can be performed by polarising terminal 50 of the starter motor with a positive voltage equivalent to the rated voltage of the system, using a conductor provided for that purpose.
5. Nebulise approximately 60 g of 30/M protective oil (10 g per litre displacement) into the turbocompressor suction inlet, during the pressurised filling operation described in the previous point.
6. Close all the suction, delivery, ventilation and bleeder openings in the engine with suitable plugs, or seal them with adhesive tape.

7. Drain the residual 30/M protective oil from the sump. This oil can be used again for a further 2 preparation operations.
8. Fit signs reading ENGINE WITHOUT OIL to the engine and to the on-board control panel.
9. Drain the coolant, if it has not been mixed with suitable antifreeze and corrosion inhibitors, and affix a sign to indicate the fact.

In the event of prolonged inactivity, the operations described must be repeated every 6 months, following the procedure given below:

- A) drain the 30/M protective oil from the sump;
- B) repeat the operations described from point 2 to point 7.

Should you intend to protect external parts of the engine, proceed by spraying OVER 19 AR protective liquid on unpainted metal parts, such as the flywheel, pulleys and the like, avoiding belts, connector cables and electrical equipment.

RESTARTING THE ENGINE AFTER A LONG PERIOD OF INACTIVITY

1. Drain the residual 30/M protective oil from the sump.
2. Fill the engine, as prescribed, with lubricant of the type and amount indicated in the table REFUELLING.
3. Drain the CFB protective fluid from the fuel circuit, carrying out this operation as indicated under point 3. of PREPARING THE ENGINE FOR A LONG PERIOD OF INACTIVITY.
4. Remove the plugs and/or seals from the suction, delivery, ventilation and bleeder openings in the engine, restoring it to a normal state of use. Connect the turbocharger suction inlet to the air filter.
5. Connect the fuel circuits to the vessel's fuel tank, completing the operations as indicated in point 4. of PREPARING THE ENGINE FOR A LONG PERIOD OF INACTIVITY. During filling operations, connect the fuel return pipe to a collection tank, so as to prevent any residual CFB protective fluid from flowing into the vessel's fuel tank.
6. Check the engine and fill it up with coolant as prescribed.
7. Start the engine and keep it running until the idling speed rate has stabilised completely.
8. Check that the instruments on the on-board control panel/s are showing plausible values, and that no alarms are shown.
9. Stop the engine.
10. Remove the ENGINE WITHOUT OIL signs from the engine and from the on-board control panel.

■ EMERGENCIES ON BOARD

The user of a vessel that has been constructed according to safety regulations, when following the instructions provided in this manual and the indications given on the engine labels, will be working in safe conditions.

Should improper conduct result in accidents, always request the intervention of trained first aid specialists immediately.

In an emergency and while awaiting the arrival of first aid specialists, follow the instructions given below.

Engine malfunctions

When navigating with a malfunctioning engine, take the greatest possible care when manouevering and make sure that all those aboard are holding firmly to safe hand-holds (see section on ENGINE MALFUNCTIONS).

In case of fire

Extinguish the fire using the fire-fighting equipment provided aboard, and in the manner indicated by Fire prevention authorities (the fire-fighting equipment required on board is compulsory under current safety legislation).

Burns and scalds

1. Extinguish any flames on the burned person's clothing, by:
 - throwing water over them;
 - using a powder fire-extinguisher, without directing the jet at the person's face;
 - covering with blankets or rolling the victim on the ground.
2. Do not attempt to remove pieces of clothing that may have stuck to the skin;
3. In the case of scalding, immediately but carefully remove any clothing that may be soaked in the hot liquid;
4. Cover the burn with a special burn dressing or sterile bandage.

Carbon monoxide intoxication (CO)

Carbon monoxide from the engine exhaust is without smell, and is dangerous both because it causes intoxication, and because when combined with air it forms an explosive mixture.

In closed rooms, carbon monoxide is extremely dangerous, as it can reach critical concentrations within a very short time.

When assisting an intoxicated person in a closed room:

1. Ventilate the room immediately, to reduce the concentration of gas.
2. When entering the room, hold your breath, do not light flames, lights or ring electric doorbells or phones, to avoid the risk of explosion.
3. Carry the intoxicated person out into the fresh air or into a well ventilated room, resting him on one side if he is unconscious.

Electrocution

The engine's electrical 12 V or 24 V electrical system does not involve the risk of electrocution, however, in the event of a short-circuit caused, for example, by a metal tool, there is a risk of burning due to overheating of the object through which the electrical current runs. In these circumstances:

1. Remove the object that caused the short-circuit, using means that provide sufficient heat insulation.
2. Switch off the power at the main switch, if there is one.

Injuries and fractures

The vast number of possible circumstances and the specific nature of operations required means that the intervention of a medical team is necessary.

1. In the event of bleeding, keep the edges of the wound pressed together until help arrives.
2. If there is any suspicion of a fracture, do not move the injured part and only move the patient if absolutely necessary.

Caustic burns

Caustic skin burns are caused by contact with extremely acid or alkaline substances.

For electric maintenance technicians these are typically caused by acid from batteries; in these circumstances, proceed as follows:

1. Remove any clothing soaked in the caustic substance.
2. Wash the area with lots of running water, avoiding parts that have not been burned.

If either battery acid, lubricants or diesel come into contact with the eyes: wash the eyes with water for at least 20 minutes, keeping the eyelids open so that the water flows over the eyeball (move the eye in all directions to wash more thoroughly).

