

DATA AND PERFORMANCE SHEET



GAS MODEL SERIES: HFGE/O 26kW (22kW) @ 60Hz
FUEL: Propane (Natural Gas)
PRIME MOVER: Ford LRG 425

Configuration	Propane	kW	Natural Gas	kW
Open	HFGE-26P1(P3)	26.0	HFGE-22N1(N3)	(22.0)
Enclosed	HFGE-26PI(P3)		HFGE-22N1(N3)	

NOTE: P1/N1 = Single Phase P3/N3 = Three Phase

Standard Specification (For stationary use only in the US)

ENGINE

Water-cooled, four-stroke Ford Gas engine model LRG 425.

Isynchronous Electronic Governor under Woodward. In static conditions, provides stability service frequency of $\pm 0.5\%$.

COOLING SYSTEM

Radiator and protected pusher fan with guards, designed for the engine cooling within ambient temperatures up to 122°F (50°C). However, the rated capacity of the genset is based on 77°F ambient temperature. Drain tap included.

ALTERNATOR

Self-regulated, auto-excited, brushless, windings treatment type for humid and saline climates. The windings have a 2/3 pitch in order to reduce the harmonic content of voltage; fixed inductor with skewed slots and a rotating inductor fitted with a damper cage. The self-regulation is obtained through an extremely reliable electronic regulator that provides a low speed and overload protection with an adjustable intervention threshold, available for 60Hz. Adjustable voltage stability with the possibility for a remote voltage regulation. 12 wires. Meets standards IEC 34-1, CEI 2-3, BS 4999-5000, VED 0530, NEMA MG1-22.

Insulation and impregnation system Insulation class H

standard. High voltage parts are impregnated with tropicalized epoxy resins by dipping and low vacuum, so that always an optimum insulation is guaranteed. In the high-power models, the stator windings undergo a further insulation.

Radio interference suppression Following the standard VDE 0875, degree "G" and "N" and with the basic safety requirements of the European regulation on electromagnetic compatibility; by applying the European standards EN 50081-1 and EN 50082-1, we comply with the above mentioned regulation.

Automatic Voltage Regulation Accuracy $\pm 1.5\%$ with load from 0 to 100% and power factor range from 0.8 to 1 with balanced load.

Overload The permissible overloads are of 300% for 20 seconds, of 50% for 2 minutes and of 10% for 1 hour.

CONTROL SYSTEM

Designed to gather the control electric instruments, alarm LED's and protections for both, engine and alternator. Built in steel sheet with a high quality painting process, to last in tropical climates and corrosive environments. Available in: key and automatic start versions. The automatic control panel allows the genset to deliver electric power a few seconds after mains failure. Once the utility supply is restored, the genset will shut down automatically.

ELECTRICAL SYSTEM

12-volt system with battery charging alternator, ground connection, starting motor, battery-mounted on the genset baseframe, with heavy-duty interconnection cables and borne protection. (Battery supplied without electrolyte).

FUEL SYSTEM

Gas. Woodward LC-50 propane vapor withdrawal.

EXHAUST SYSTEM

Exhaust silencer kit, vertical silencer, clamps and exhaust pipe. (Supplied loose), for open skid version. Residential silencer is standard for soundproofed versions.

MOUNTING ARRANGEMENT

Electro-welded structural quadrangular chassis in coated black steel profiles according to UNE 36.537 and DIN 17.119, 17.120 and 59.411 standards, fitted with anti-vibration supports isolating the perfect aligned engine-alternator with the baseframe. Fan protection guard, and front guard for radiator are included. In the soundproofed gensets, the canopies are manufactured in sheet metal providing low sound emission levels and protecting the genset from external damage. The rock wool isolating material used is non-combustible, non-corrosive to the metals and very durable.

A rock wool net has been installed in the doors in order to enable its cleaning and washing. This special net is also fire-resistant. All doors are lockable with safety key. For the best convenience at loading, unloading, and installation, the HIMOINSA gensets are provided of a strong lifting hook and forklift rails.

DOCUMENTATION

Full set of engine, alternator, and genset maintenance and installation manuals, as well as electric circuit wiring diagrams. Testing certificate is available upon request.

FACTORY TEST

Before dispatch, all gensets are tested in our high technology load banks. The proper performance of the genset and its control and measurement instruments are also checked.

WARRANTY

All equipment is guaranteed for a period of 12 months from invoice date. Warranty terms and conditions are available upon request.

Weight: 2,722 lbs.

Dimensions: 89 x 42 x 53 in

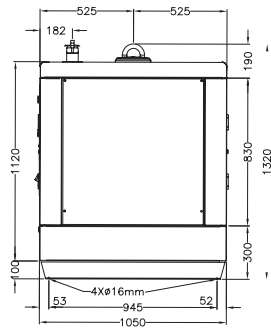

LEFT SIDE VIEW

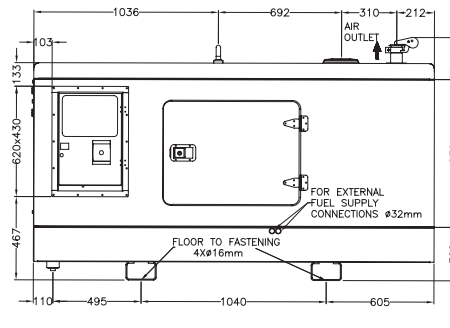

FRONT VIEW

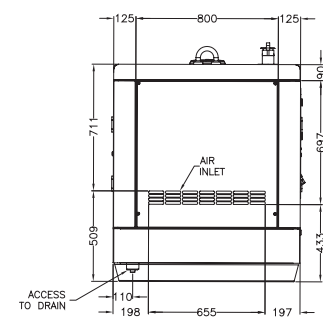

RIGHT SIDE VIEW

Generating set performance

60Hz

Specification details		Max. Standby Power (F.S.P.) (2)	Prime Power (P.R.P.) (1)
Rated output at 0.8 p.f.	kW	26 (22)	23.4 (19.8)
Rated speed	r.p.m	1,800	
Voltages available	V	120/240; 480/277; 208/127	

Propane (Natural Gas)

Ambient reference conditions: 1,000 mbar, 80.6°F, 30% relative humidity.
 * The indicated performance may change according to the alternator model.

Prime mover performance

1,800 r.p.m.

Specification details		Max. Standby Power (F.S.P.) (2)	Prime Power (P.R.P.) (1)
Rated output	BHP	41 (35)	36.9 (31.2)
BMEP	psi	124	---
Mean piston speed	ft/min	1,020	---
Flywheel Housing		SAE 4	

Ambient reference conditions: 1,000 mbar, 77°F, 30% relative humidity.
 * Net performance at flywheel with tolerance of ±3% and available after ~50 hours running.

(1) Prime Power (P.R.P.) - ISO 8528: prime power is the maximum power available during a variable power sequence, which may be run for an unlimited number of hours per year, between stated maintenance intervals. The permissible average power output during a 24-hour period shall not exceed 80% of the prime power. 10% overload available for governing purposes only.

(2) Max Stand-by power (ISO 3046 Fuel Stop power): power available for use at variable loads for limited annual time (500h), within the following limits of maximum operating time. 100% loads 25 h per year - 90% loads 200 h per year.

No overload available. Applicable in case of failure of the main in areas of reliable electrical network.

Prime mover data		
Manufacturer		Ford
Model		LRG 425
Spark ignition		Ford DIS
Aspiration type		Naturally Aspirated
Cylinders, number and arrangement		I-4
Bore x stroke	in (mm)	3.78 x 3.40 (96.0 x 86.3)
Total displacement	in ³ (L)	153 (2.5)
Cooling system		Liquid Coolant
Lube oil specification		API 5H
Fuel consumption @ F/L	CFH	148
Oil consumption		TBD
Speed governor		Woodward LC-50 Isochronous
Air filter		Dry

Synchronous generator*		
Poles	N°	4
Phases	N°	3+N
(Standard) winding connections		Series Star
Frame mounting		B - 2
Cooling		by ventilating fan
Windings treatment	type	for humid and saline climates
Insulation	class	H
Damper windings		for parallel
Enclosure (according to IEC 34-5)		IP 21
Waveform distortion		no more than 5%
Overexcitation device (option)		per Icc 3 In
Exciter		Brushless excited design with solid state
Voltage regulator		Static electronic design
Steady voltage precision		within +/-1.5% from no load to full with cos = .08/1

* Alternators used by HIMO/INSA Gensets meet the requirements of following standards: ISO 8528; IEC 34-1; CEI 2-3; VDE 0530; BS 4999-5000; NF 51-100
* Ambient reference conditions: 1,000 mbar, 80.6°F, 30% relative humidity

Generating set installation data

EXHAUST SYSTEM		
Max. exhaust temperature at full load	°F	1,100
Exhaust gas flow	CFM	227
Heat rejected to exhaust & radiant	Btu/min.	3,240
Maximum allowable back pressure	in H ² O	20
	mm H ² O	510
ENGINE ROOM AIR REQUIREMENT		
Fan air flow	CFM	2,700
Air requirement for combustion at 100% load/rated speed	CFM	77
COOLING SYSTEM		
ATB (without canopy) - nominal rating	°F	122
	°C	50
Heat rejected to coolant	Btu/min	1,120
ELECTRIC STARTING SYSTEM		
Cranking motor rating	kW	TBD
Minimum recommended battery capacity	ccA	550
Auxiliary voltage	Vcc	12
LIQUID CAPACITY (REFILL)		
Lube oil total system including sump, filters, etc.	qts	4.5
	L	4.3
Cooling system capacity total	qts	13.8
	L	13.0
GENERATING SET TRANSPORT DATA		
Basic data Soundproofed genset		
Shipping volume seaworthy packing	ft ³	187.3
Dry weight (with standard accessories)	Lb	3,935

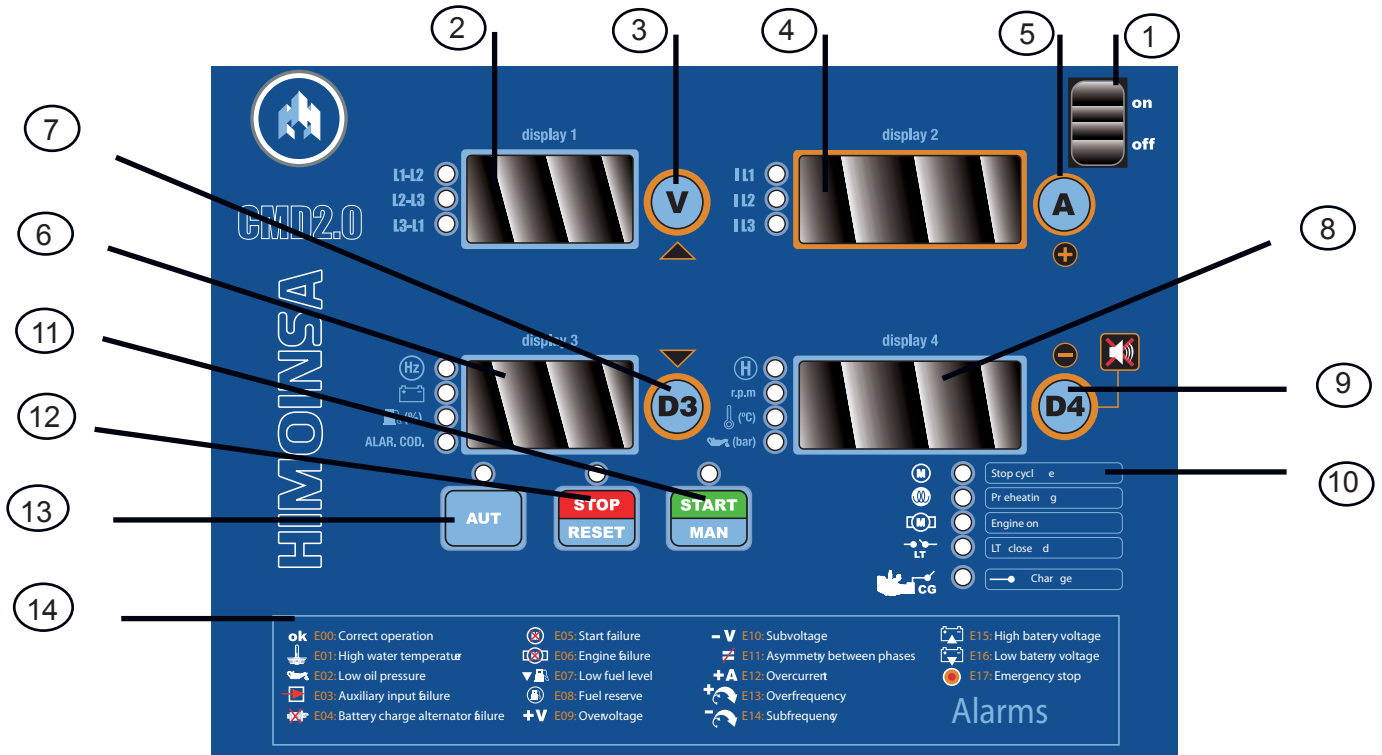

1. Switch-on button.
2. Display 1, phase voltage visual display.
3. Push-button V. to select voltage.
4. Display 2, Amperage visual display.
5. Push-button A, Phase amperage selector.
6. Display 3, Visual display for frequency, battery level fuel level or alarm code.
8. Display 4, visual display of working hours, speed meter water level temperature or oil level temperature.
9. Push-button D4, selects hour meter, speed indicator, water level temperature, oil level pressure.

- 10.1 Stopping cycle indicator.
- 10.2 Preheating indicator.
- 10.3 Engine on indicator.
- 10.4 LT Closed indicator.
11. Push-button mode START/MAN.
12. Push-button mode STOP/RESET.
13. Push-button mode AUT (automatic operation)
14. Alarm Codes, shown on display 3.

E00: Correct operation	E09: Over voltage
E01: High water temperature	E10: Under voltage
E02: Low oil pressure	E11: Asymmetry btwn. phases
E03: Auxiliary input failure	E12: Over current
E04: Battery charge alt. failure	E13: Over frequency
E05: Start Failure	E14: Underfrequency
E06: Engine Failure	E15: High battery voltage
E07: Low fuel level	E16: Low battery voltage
E08: Fuel reserve	E17: Emergency stop

Optional accessories

- UL-Listed circuit breakers
- 120-volt water jacket heater
- Digital timer - autostart only
- Battery chargers
- Extended warranty for certain standby applications

Distributor:



Himoinsa USA, Inc.
16210 West 110th Street
Lenexa, KS 66219
Tel: 913-495-5557
Fax: 913-495-5575
www.himoinsausa.com info@himoinsausa.com