

Oxx Power™ Industrial Engines

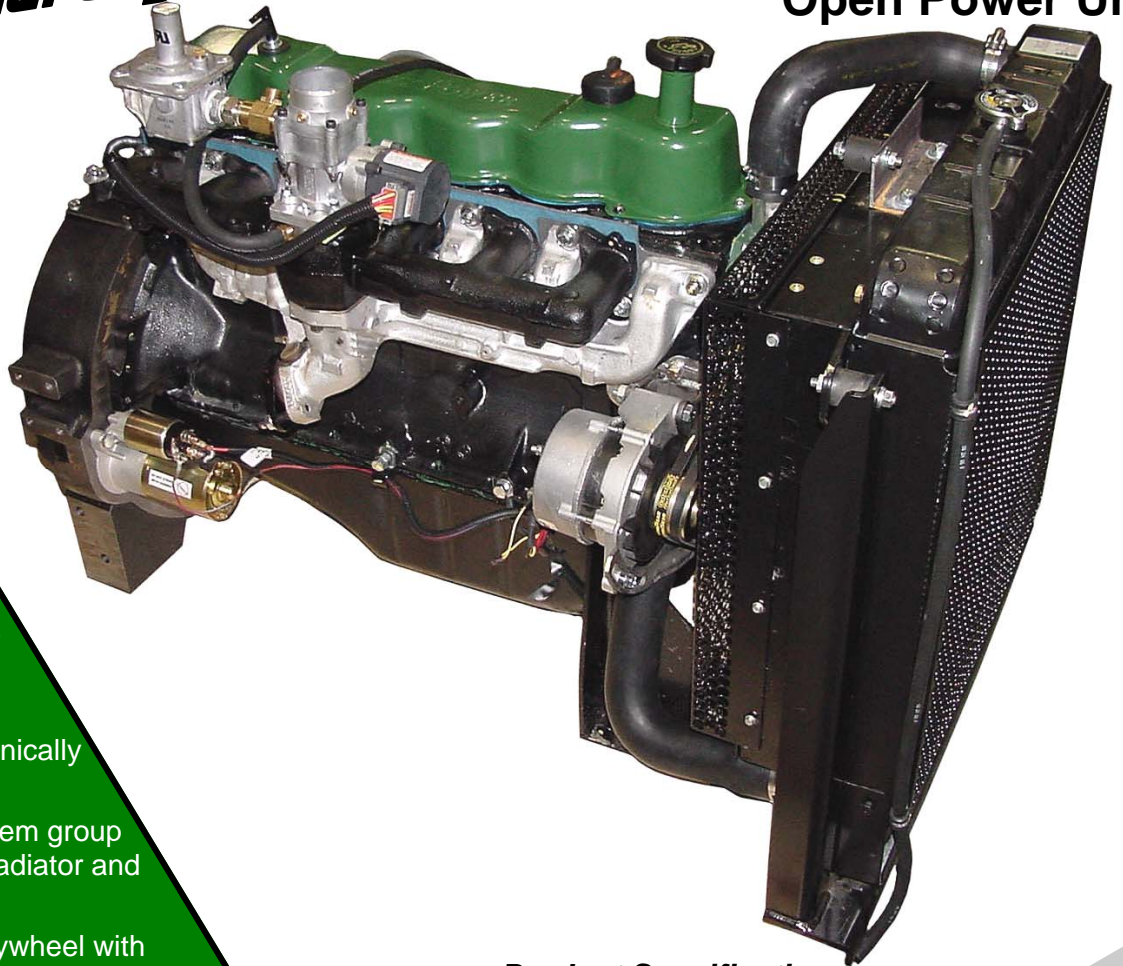

HEC649I-OPU

4.9L

6-Cylinder
Open Power Unit

Standard Equipment

- Heavy Duty Oxx Power industrial engine.
- Woodward LC50 electronically governed fuel system.
- Hi-Capacity cooling system group with isolation mounted radiator and painted steel frame.
- Cast iron SAE-3 11.5" flywheel with matching housing.
- Cast Iron intake and exhaust manifolds.
- Electronic distributor with coil, ICM, spark plugs and wires.
- 65 AMP heavy duty alternator.
- Denso type PMGR starter.
- Hardened valves and seats in cylinder head for prolonged life with dry fuels.
- Extra heavy duty center sump oil pan with 6 quart capacity.
- All Oxx Power engines are dyno tested to ensure performance and come with a 3 year or 3000 hour warranty.

Product Specifications

Engine Type.....	Inline 6-cyl
Bore & Stroke.....	4.03" X 3.98" (102.1 X 101.1mm)
Displacement.....	4.98L (305 CID)
Compression Ratio.....	9.0:1
Oil Capacity.....	7 qts. (6.6 L) including filter
Net Weight.....	600 lbs. (272 Kgs.)
Fuel.....	LPG & Natural Gas
Horsepower.....	118 @ 3600 (propane)
.....	110 @ 3600 (natural gas)
Torque (ft-lbs).....	210 @ 2000 (propane)
.....	200 @ 2000 (natural gas)

Specifications subject to change without notice.

PowerTech Engines Inc.

2933 East Hamilton Ave., Fresno, CA 93721
Tel: 1-800-891-1776, Fax: 559-264-2933
power@powertechengines.com

By

HEC

Hydrogen Engine Center



Power Unit Dimensions

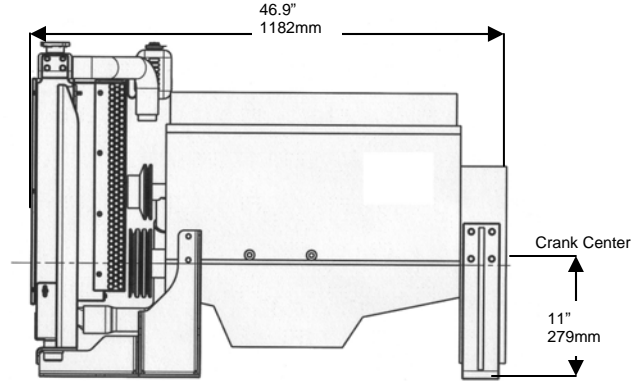
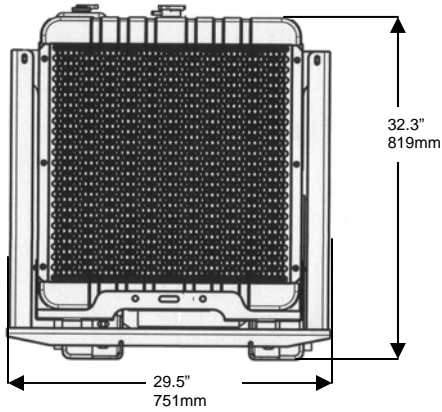

Optional Equipment

SAE-3 Manual PTO



Deluxe panel with switch gauges

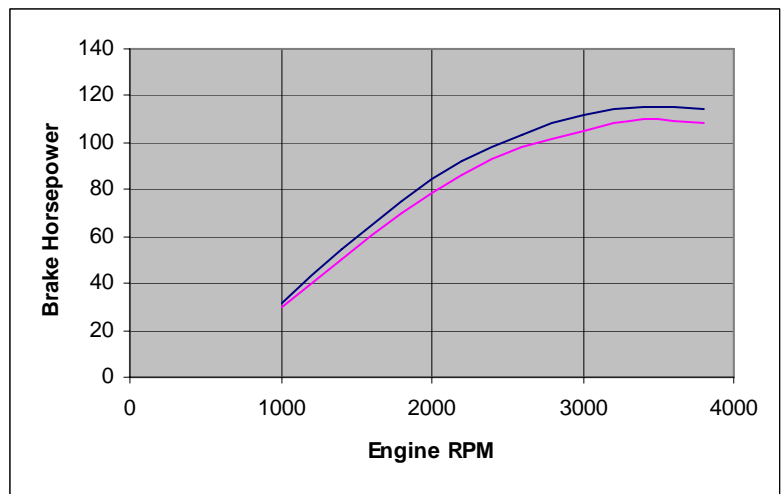

BHP Propane

BHP Natural Gas

Typical Power Curves
Actual power will depend upon fuel system used and engine tuning

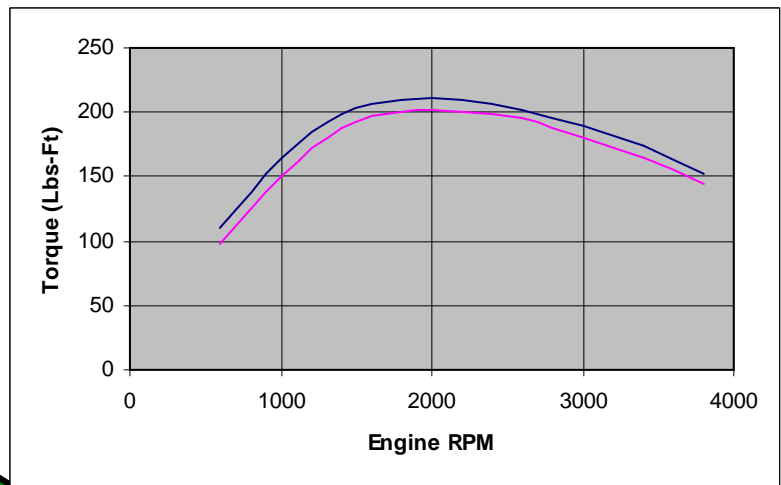

Torque Propane

Torque Natural Gas

Powertech Engines Inc.
2933 East Hamilton Ave., Fresno, CA 93721
Tel: 1-800-891-1776, Fax: 559-264-2933
power@powertechengines.com

Power Curves
Corrected per SAE J1995