

WSG-1068

6.8-Litre 10-Cylinder



Options

Lifting Eyes

Flywheels

- 11.5" (292.1 mm) over-center
- 12.0" (304.8 mm) flat-faced

Flywheel Housings

- SAE #3 with feet, without side mounting pads
- SAE #3 with side mounting pads without feet
- SAE #3 with feet and side mounting pads

Clutch

- 12.0" (304.8 mm) spring loaded

Rubber Isolated Engine Support Brackets

- left-hand and right-hand

Ignition Control Module Harness

Generator

- 12V 110 AMP

Stainless Steel Exhaust Manifolds

Starter

FEAD with Single Serpentine Belt

Warranty

Contact Ford Power Products
for warranty details.

Specifications

Engine Type.....	V-10
Bore and Stroke.....	3.55 in x 4.17 in (90.2 mm x 105.8 mm)
Displacement.....	6.8 Litre (415 CID)
Compression Ratio.....	9:1
Oil Capacity.....	6 qts including filter (4.26 litres)
Net Weight.....	640 Lbs. (290 Kgs.)
Base Engine Dimensions.....	H 30.4" x L 28.5" x W 31.7" (772.6 mm x 723.5 mm x 805.1 mm)

Natural Gas (Corrected per SAE J1995)

Fuel Specification.....	1050 BTU/FT3
Intermittent Gross Power.....	225 HP @ 3600 RPM (168 kW @ 3600 RPM)
Continuous Gross Power.....	160 HP @ 3000 RPM (119 kW @ 3000 RPM)
Intermittent Gross Torque.....	336 Ft. Lbs. @ 3400 RPM (456 Nm @ 3400 RPM)
Continuous Gross Torque.....	283 Ft. Lbs. @ 2000 RPM (384 Nm @ 2000 RPM)

*Data acquired using FPP specified open loop fuel system

Liquefied Petroleum Gas (Corrected per SAE J1995)

Specification.....	HD-5
Intermittent Gross Power.....	223 HP @ 3600 RPM (166 kW @ 3600 RPM)
Continuous Gross Power.....	165 HP @ 3000 RPM (123 kW @ 3000 RPM)
Intermittent Gross Torque.....	343 Ft. Lbs. @ 3150 RPM (465 Nm @ 3150 RPM)
Continuous Gross Torque.....	289 Ft. Lbs. @ 3000 RPM (391 Nm @ 3000 RPM)

*Data acquired using FPP specified open loop fuel system

Standard Features / Benefits

Composite Valve Train Covers for reduced noise and resistance to corrosion

Hydraulic Lash Adjusters with Roller Finger Cam Followers for minimal friction and improved performance

Tubular Cams with Powder Metal Lobes for strength and durability

Single Overhead Cams with Silent Timing Chain Drive System for reduced noise, friction and increased durability

Aluminum Cylinder Heads with Long Reach Mounting Bolts into Main Bearing Bulkhead to maintain resistance to heat distortion

Optimized Combustion Process for reduced emissions and improved efficiency

Stainless Steel Cylinder Head Gaskets for resistance to corrosion and increased cylinder block to cylinder head sealing

Deep Skirted Cast Iron Block for strength and durability

Doweled, Cross-Bolted Four-Bolt Main Bearing Caps for increased strength

Forged Steel Crankshaft for increased strength and durability

Split Pin Crankshaft Journals for smooth engine operation

Powder Metal Connecting Rods for high strength

Hypereutectic Pistons with Teflon Coated Skirts and Low Tension Rings for reduced friction horsepower requirements

Even Firing Order with Internal Balance Shaft for vibration-free operation

Tuned Split-Plenum Intake delivers significantly more torque and/or power throughout the engine speed range

High Flow Water Pump for maintaining optimum coolant flow

Coil on Plug Ignition System for reliable and effective spark delivery



The Source for Power...
Worldwide™

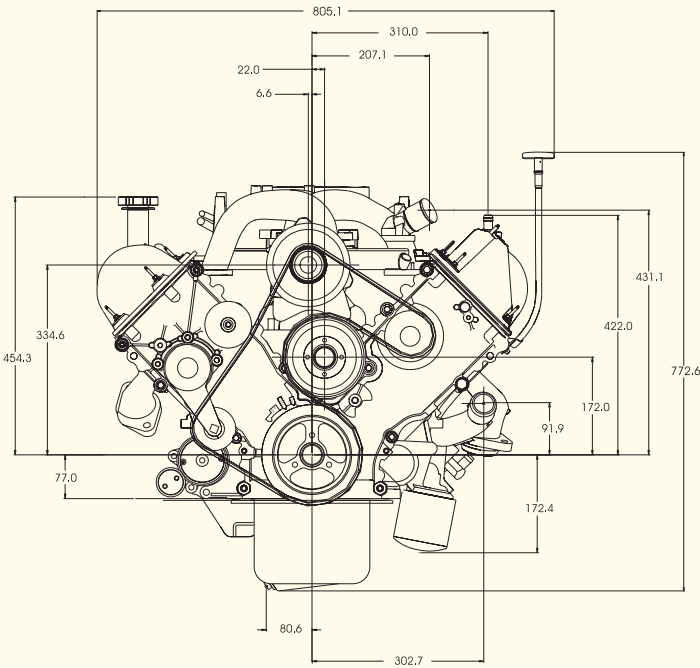

Front End View

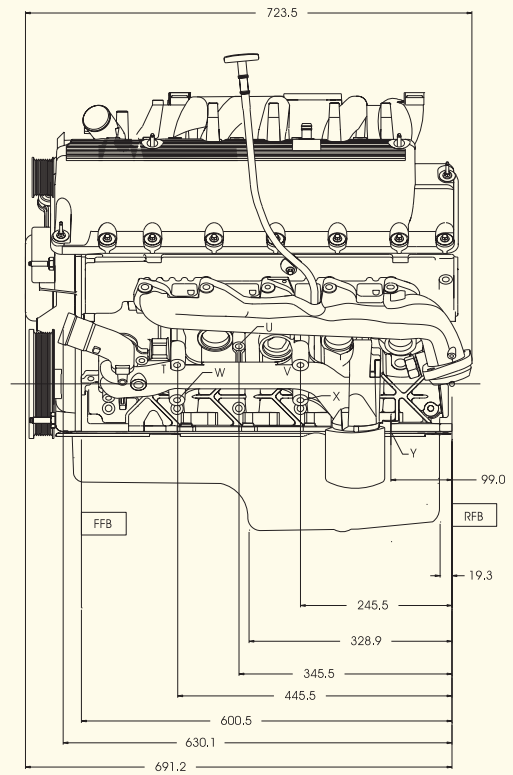

Left Side View

Measurements	mm
--------------	----

Power Curves (corrected per SAE J1995)

Natural Gas:

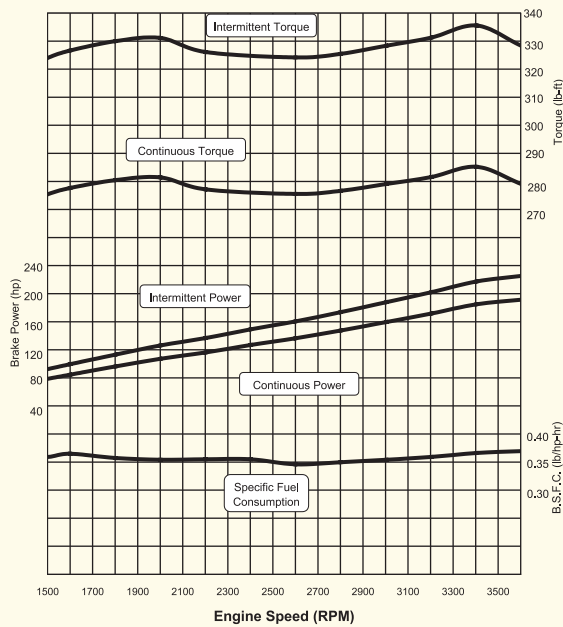

Liquefied Petroleum Gas:

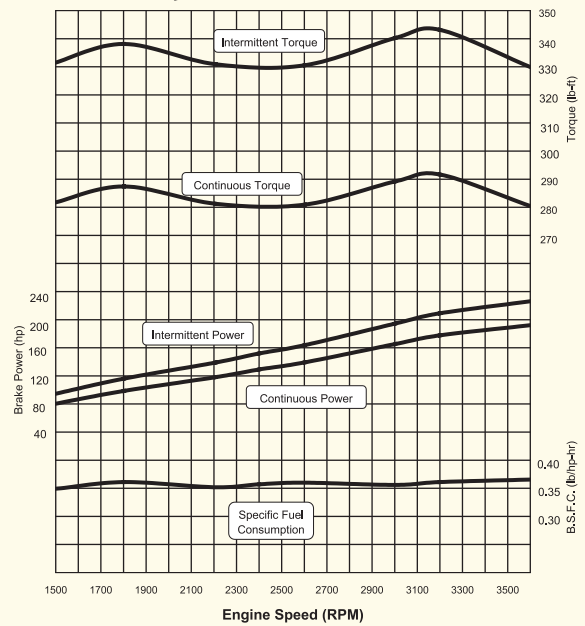

Specifications are subject to change without notice.
Some Ford engines are produced for Ford by other companies.



The Source for Power...
Worldwide™

Contact Ford Power Products or your local
FPP distributor for additional information

Ford Power Products
15700 Lundy Parkway Drive
Suite 200
Dearborn, Michigan 48126
Phone: 1-800-833-4773
Fax: 1-313-619-2600

Corporate Web Site: www.fordpowerproducts.com