

ISD-873

Generator Power Unit

7.3-Litre

V-8 Power Stroke™



Emissions Information

EPA Emissions Certification Pending

Warranty

Contact Ford Power Products for warranty details.



The Source for Power...
Worldwide™

Specifications

Engine Type	V-8
Bore and Stroke	4.11 in x 4.18 in (104.4 mm x 106.2 mm)
Displacement	7.3 Litre (444 CID)
Compression Ratio	17.5:1
Oil Capacity	20 Qts (19.0 litres)
Net Weight	930 Lbs (422 Kgs.)
Base Engine Dimensions	H 36.7" x L 36.3" x W 33.2" (932.2 mm x 922.0 mm x 843.3 mm)

Diesel

Fuel System	HEUI (Hydraulic Electronic Controlled Unit Injection)
Peak Torque @ 1500 RPM	420 Lb-Ft & 650 Lb-Ft (569 Nm & 881 Nm)
Intermittent Power @ 1800 RPM	176 HP & 215 HP (131 kW & 160 kW)

Standard Features/Benefits

Leading choice in North America for diesel powered super duty pick-up trucks

Gear-Driven Engine Timing Components for trouble-free operation, greater reliability and durability

Hydraulic Tappets with Roller Followers eliminate the need for valve lash adjustment

Plateau-Honed Cylinder Bores contribute to long bore life, superior oil control and uniform piston ring lubrication

Forged Micro-Alloy Steel Crankshaft Fillets and Journals are induction-hardened for strength and durability

Large Bearing Surfaces ensure long engine life

Advanced Manufacturing Processes ensure precision and uniformity

Forged Steel Connecting Rods with Large Bearing Surfaces provide exceptional strength and long engine life

Piston Cooling Jets provide optimum temperature control and lubrication, resulting in long engine life

Keystone Plasma-Faced Top Ring minimizes oil consumption and emissions while increasing power cylinder life

Standard Electronic Glow Plugs provide unaided cold starts down to -20 degrees F / -28 degrees C

Optimized Turbocharger provides powerful, economical and quieter operation

Air-to-Air Intercooling on All Ratings provides maximum efficiency, fast response and consistent performance at virtually any altitude

Generator Power Unit Ratings

Available Continuous KVA Ratings

- 150
- 180

Flywheel Housings

- SAE #2
- 2.88" (73.1 mm) pilot hole in adapter

Serpentine Belt Drive System

65 Amp Alternator

12 V Starter

Dual V-belt Crankshaft Pulley for up to a 50 HP Load

International (Siemens) Engine Controller

Oil Filter

Lube Oil Pre-heater

Oil Cooler

Fuel Filter

Fuel/Water Separator

Fuel Transfer Pump

Fuel Heater

Engine Wiring Harness with Sensors

Engine Cooling Package

- radiator
- charge air cooler
- fan (suction or pusher)
- fan guard

Engine Stands

Air Filter

Muffler

Control Panel

- key switch
- voltage gauge
- oil pressure gauge
- water temp gauge
- potentiometer throttle control
- tachometer
- emergency shut-off control

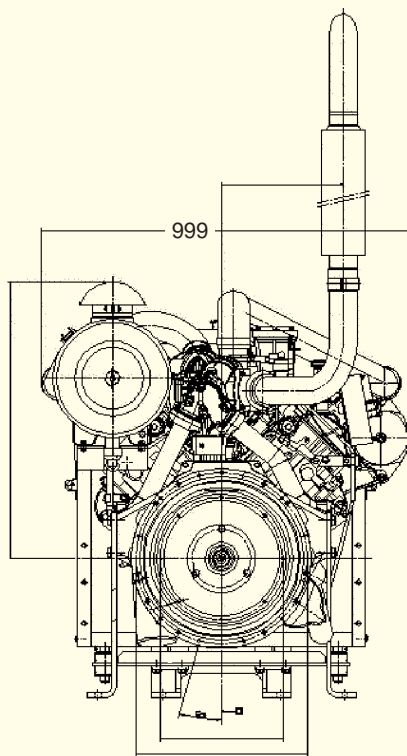

Front End View

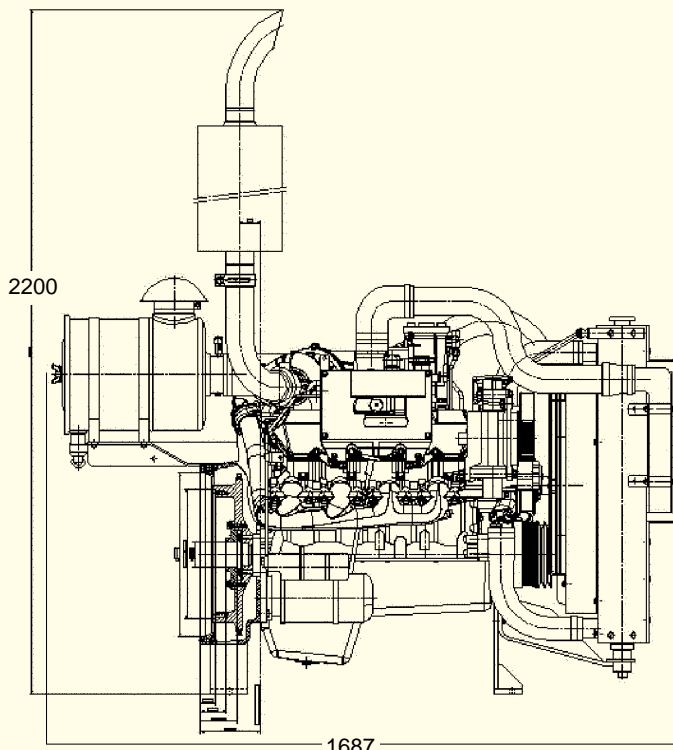

Left Side View

Measurements	mm
--------------	----

Power Curves (corrected per SAE J1995)

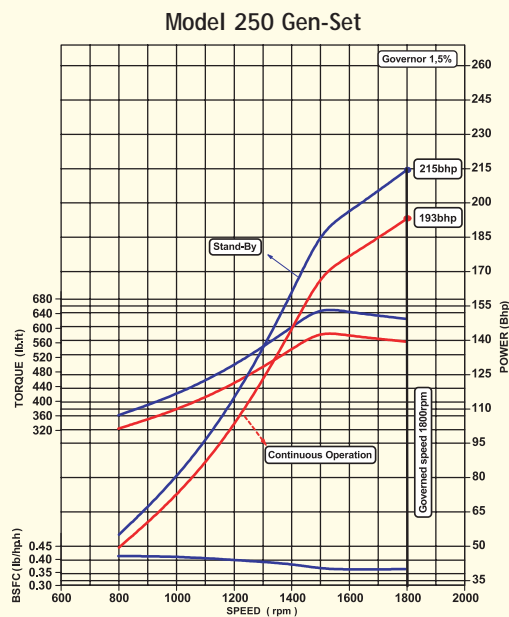
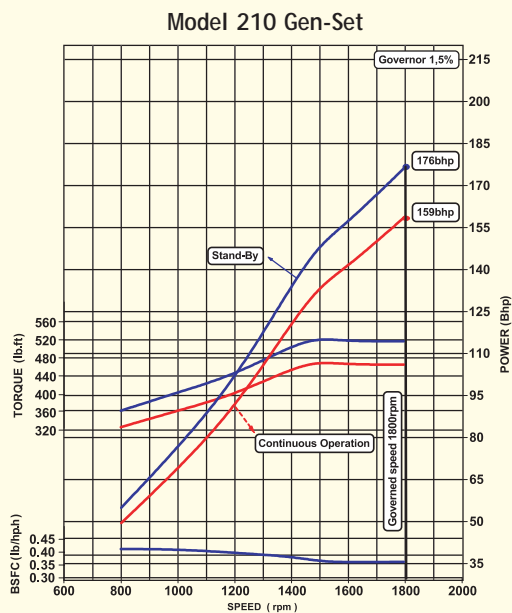

Specifications are subject to change without notice. Some Ford engines are produced for Ford by other companies.



The Source for Power...
Worldwide™

Contact Ford Power Products or your local FPP distributor for additional information

Ford Power Products
15700 Lundy Parkway Drive
Suite 200
Dearborn, Michigan 48126
Phone: 1-800-833-4773
Fax: 1-313-619-2600

Ford Power Products GmbH
Stolberger Str. 313
D-50933 Köln, Germany
Phone: 49-221-94700 562
Fax: 49-221-94700-560

Corporate Web Site: www.fordpowerproducts.com

Ford Power Products Ltd.
20/586 Arisdale Avenue
South Ockendon
Essex, RM 15 5TJ England
Phone: 44-1708-672 677
Fax: 44-1708-672-349