

# LRG-425

## Carbureted

### 2.5-Litre

### 4-Cylinder



#### Options

##### Engine Cooling Fans

- 16.5" (419.1 mm) diameter suction
- 16.0" (406.4 mm) diameter pusher

##### Flywheels

- 8.0" (203.2 mm) over-center clutch
- 8.5" (215.9 mm) spring-loaded clutch
- 9.0" (228.6 mm) spring-loaded clutch

##### Flywheel Housings

- SAE #4 and #5
- clutch housings

##### Power Take-Off (PTO)

- 8.0" (203.2 mm) over-center clutch
- 9.0" (228.6 mm) spring-loaded clutch

##### Exhaust Manifolds

- center dump side
- rear dump down

##### Dry-Type Industrial Air Cleaners

##### Power Steering Pump

##### Oil Cooler

##### Engine Supports (rubber isolated mounts)

##### Governors

- mechanical, variable speed or constant speed
- electronic, 3-speed programmable

##### Electronic Fuel Injection LRG-425 Engine Available

#### Transmissions

Accompanying transmissions are available for the LRG-425 through Ford Power Products.

#### Warranty

Contact Ford Power Products for warranty details.



The Source for Power...  
Worldwide™

#### Specifications

Engine Type.....	I-4
Bore and Stroke.....	3.78 in x 3.40 in (96.0 mm x 86.3 mm)
Displacement.....	2.5 Litre (153 CID)
Compression Ratio.....	9.37:1
Oil Capacity.....	4.5 qts including filter (4.26 litres)
Net Weight.....	339 Lbs. with accessories (154 Kgs.)
Base Engine Dimensions.....	H 26.9" x L 26.5" x W 21.4" (682.8 mm x 672.5 mm x 542.4 mm)

#### Gasoline (Corrected per SAE J1995)

Fuel Specification.....	87 A.K.I.
Intermittent Gross Power.....	87 HP @ 3600 RPM (65 kW @ 3600 RPM)
Continuous Gross Power.....	74 HP @ 3600 RPM (55 kW @ 3600 RPM)
Intermittent Gross Torque.....	130 Ft. Lbs. @ 2400 RPM (176 Nm @ 2400 RPM)
Continuous Gross Torque.....	111 Ft. Lbs. @ 2400 RPM (150 Nm @ 2400 RPM)

#### Natural Gas (Corrected per SAE J1995)

Fuel Specification.....	1050 BTU/FT3
Intermittent Gross Power.....	76 HP @ 3600 RPM (57 kW @ 3600 RPM)
Continuous Gross Power.....	64 HP @ 3600 RPM (48 kW @ 3600 RPM)
Intermittent Gross Torque.....	120 Ft. Lbs. @ 2800 RPM (163 Nm @ 2800 RPM)
Continuous Gross Torque.....	102 Ft. Lbs. @ 2800 RPM (138 Nm @ 2800 RPM)

#### Liquefied Petroleum Gas (Corrected per SAE J1995)

Fuel Specification.....	HD-5
Intermittent Gross Power.....	90 HP @ 3600 RPM (67 kW @ 3600 RPM)
Continuous Gross Power.....	76 HP @ 3600 RPM (57 kW @ 3600 RPM)
Intermittent Gross Torque.....	135 Ft. Lbs. @ 2200 RPM (183 Nm @ 2200 RPM)
Continuous Gross Torque.....	115 Ft. Lbs. @ 2200 RPM (156 Nm @ 2200 RPM)

#### Standard Features / Benefits

**Electronic, Distributorless Ignition Control Module** optimizes industrial applications

**Carbureted Downdraft Fuel System** for optimized fuel distribution

**Cast Iron Cross Flow Type Cylinder Heads** offering excellent breathing characteristics, increased performance and fuel economy for multi-fuel operation

**Cast Iron Cylinder Block with Full-Length Water Jackets** resulting in long engine life

**Nodular Cast Iron Crankshaft** is extremely rigid for increased durability

**Overhead Camshaft with Roller Cam Followers** for reduced friction and improved fuel efficiency

**Pressurized Lubricated Bearings and Tappets** with oil mist and splash to cylinder walls and piston rings for maximum internal component lubrication

**Pressure-Type, By-Pass Circulation Cooling System** for maximum cooling control

**Water Pump Delivery of 24.4 gal/min (92.3 litre) @ Pump RPM of 2800** ensures a generous protective engine cooling range

**Internally Regulated 12-V Negative Ground, 90-AMP Alternator** providing modern, compact charging system while minimizing bulky wiring harnesses

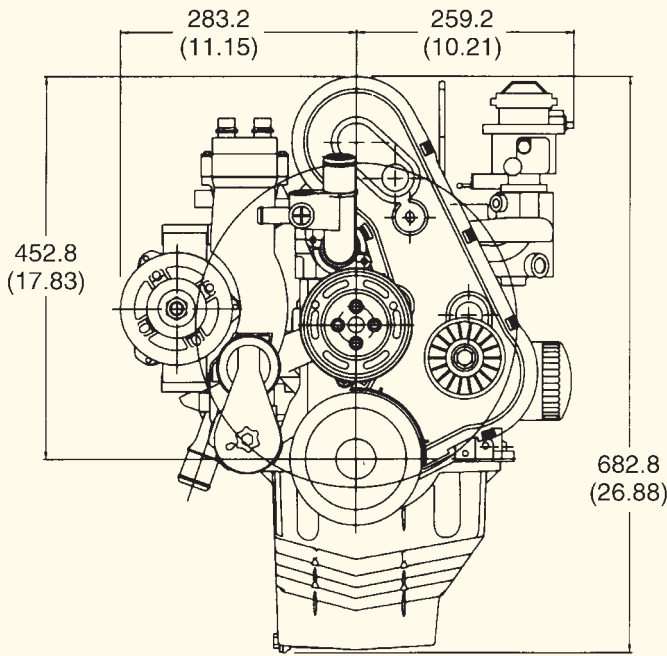

Front End View

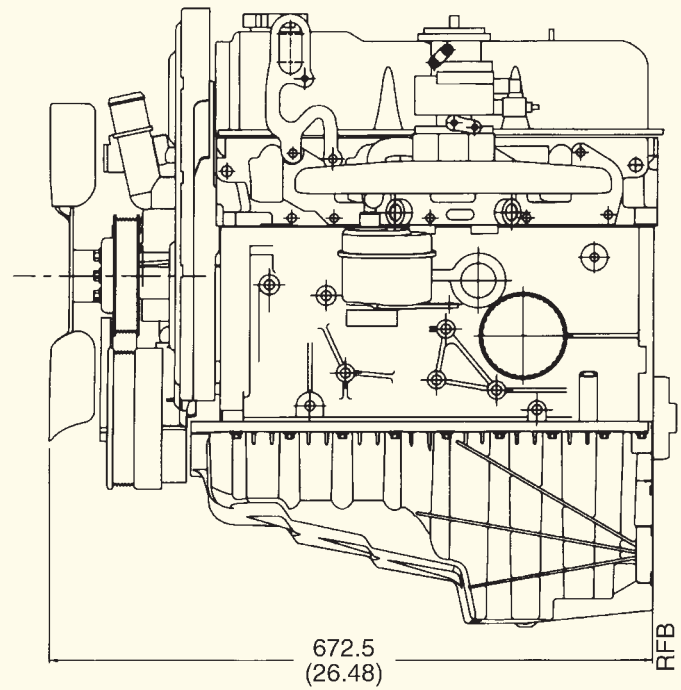

Left Side View

Measurements	mm (in")
--------------	-------------

## Power Curves (corrected per SAE J1995)

### Gasoline:

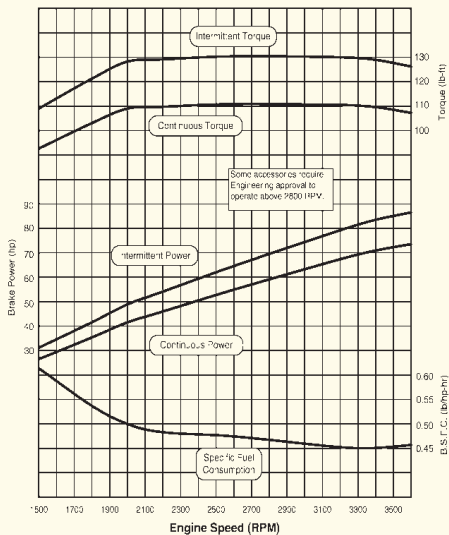

### Natural Gas:

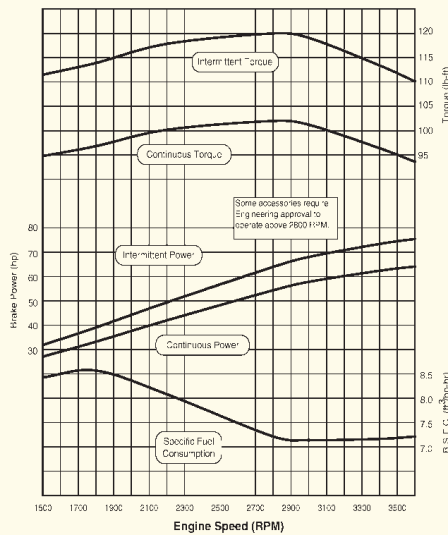

### Liquefied Petroleum Gas:

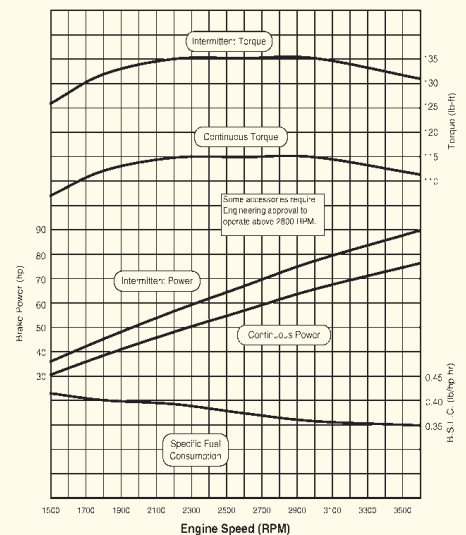

The Source for Power...  
Worldwide™

Contact Ford Power Products or your local FPP distributor for additional information

Ford Power Products  
15700 Lundy Parkway Drive  
Suite 200  
Dearborn, Michigan 48126  
Phone: 1-800-833-4773  
Fax: 1-313-619-2600

Ford Power Products GmbH  
Stolberger Str. 313  
D-50933 Köln, Germany  
Phone: 49-221-94700-551  
Fax: 49-221-94700-560

Corporate Web Site: [www.fordpowerproducts.com](http://www.fordpowerproducts.com)

Ford Power Products Ltd.  
20/586 Arisdale Avenue  
South Ockendon  
Essex, RM 15 5TJ England  
Phone: 44-1708-672-678  
Fax: 44-1708-672-349

Specifications are subject to change without notice.  
Some Ford engines are produced for Ford by other companies.